

HIWATTTM

OWNERS MANUAL

**THIS MANUAL COVERS MODEL NUMBER
DR103**

Distributed Worldwide by HIWATT Amplification International

Distributed in the United States by HIWATT Amplification USA

Manufactured in England by the Audio Brothers

INTRODUCTION

These amp heads are as exact a replica as possible of the **HIWATT™** DR103's that were built in the early seventies under the ownership of Dave Reeves.

A look inside the amplifier will reveal point to point hand wiring, turret tag boards (no printed circuits), and hand laced wiring harnesses. The circuit diagram at the back of this manual will confirm that Dave Reeves original circuit has been very closely adhered to, the 1975 version to be precise. The power transformers and output transformers are manufactured by Partridge, the original 1970's supplier, to the original design sheets. The components and wires are the modern available equivalents of the vintage components, 1 Watt carbon resistors, and wound polyester capacitors being used throughout.

Because the components are modern and English valve manufacturers no longer exist there are slight unavoidable differences in the absolute electrical and sound qualities of this design. In measurement terms your **HIWATT™** head is however as close to the original as it is possible to build and the sound will not disappoint even the most discerning **HIWATT™** enthusiast. This amplifier has been handbuilt by people who care, and we trust that it will give you much pleasure over many years.

HIWATT AMPLIFICATION INTERNATIONAL

BEFORE OPERATING THIS EQUIPMENT:

YOUR SAFETY IS PARAMOUNT: EXTREMELY HIGH VOLTAGES EXIST IN THIS AMPLIFIER AND THERE ARE NO USER SERVICEABLE PARTS. FOR MAINTENANCE OR IN THE UNLIKELY EVENT OF A REPAIR BEING REQUIRED, REFER TO YOUR NEAREST **HIWATT™ DEALER. DO NOT OPERATE THE AMPLIFIER WITH ANY OF THE COVERS REMOVED.**

1. Check that the voltage selector is set to the correct wall voltage.
Note: Users in the United States may wish to measure the actual wall voltage before choosing between 100V and 117.5V as supplies can vary quite dramatically.
2. Always use an earthed supply.
3. Always connect a loudspeaker system of the correct impedance (4, 8, or 16 Ohms) and set the impedance selector to that value **prior** to switching on the amplifier. Use only correct two-core loudspeaker cables terminated with mono jack plugs. Use of co-axial leads like guitar leads will invalidate the warranty and may damage the amplifier. In common with all valve amplifiers it is vital that the amplifier is not operated into an open circuit.
4. Check that the correct fuses are fitted in the fuseholders on the rear panel (See the specification sheet at the end of this manual for the correct fuse ratings for your model).
5. Before switching the amplifier on ensure that the standby switch is in the off position.

OPERATION

The DR103 heads are suitable for guitar or bass amplification, with passive or active pickups. Although these heads are primarily designed for clean sounds they may be overdriven with any competently designed effector to give other sounds. With the NORMAL VOL or BRILL VOL full on you may find that some high gain pickups and active systems will give a distorted signal. The upper input on each channel will give the cleaner sound.

The tone controls operate on either input and the presence control allows an extremely bright and aggressive sound to be selected at the upper end of the setting. Experienced **HIWATT™** users will confirm that this was always the case. All the inputs may be used

simultaneously (just like the old bands did), your ears will tell you what is a viable combination.

SOME DOs AND DON'Ts

DO always use the standby switch when switching on the amplifier. Switching on an amplifier with EL34 output valves without using the standby can seriously reduce the valve life. Allow the amplifier to warm up for two minutes before switching the standby on. The standby can also be used as a mute, for tuning or a quick string change.

DO always check the voltage and impedance settings especially when touring or in a studio setting.

DO have the output tubes replaced regularly and use only matched sets of EL34's.

The output valves affect the sound of the amplifier and different players like different tubes. An average set of quality valves should last for approximately 2000 hours of use ie 5 hours a day for a year. This is the maximum period for a good original sound. Valves degrade so slowly that you will not notice day to day but after 1000 hours you would immediately notice if you fitted a new set. You may however prefer the mellower, mushier sound of an old set. We would recommend the annual replacement of the output valves, and quality matched sets of **HIWATT™** valves are available from your dealer. As for the preamp valves we recommend that you follow the " if it ain't broke don't fix it" rule. Many old valve amps still have their original preamp tubes after 15, 20 or even 30 years. These tubes can be changed, but we recommend that they are kept in until they cause trouble. Symptoms of this are noise, popping, and microphonic squeals or rattles through the loudspeaker. Always carry spare tubes and fuses as you would guitar strings. **Always disconnect the amplifier from the mains and allow the valves, all of which run very hot, to cool prior to replacing them.** Do not replace the ECC81 with an ECC83 as this will produce an extremely unstable high frequency response that will not be controllable.

DO have the amplifier serviced regularly by a qualified valve amp technician, especially if you are going to have to rely on it for important work. As with your car the key to safety and reliability is regular maintenance. Service facilities are available from your **HIWATT™** dealer.

DON'T attempt to repair or modify a **HIWATT™** product yourself. Only authorised dealer or distributor repairs are acceptable in warranty claims, and HIWATT AMPLIFICATION INTERNATIONAL wholly and exclusively relinquish all responsibility for any unit not maintained by an approved and authorised **HIWATT™** service agent, or modified or misused in any way.

DON'T operate the amplifier without an earth.

DON'T cover the amplifier or block the air vents.

DON'T put drinks on top of the amplifier or allow any liquid to fall in it - cracked tubes are the inevitable result.

DON'T Store the amplifier in damp or dusty conditions.

CLEANING

Do not attempt to clean any part of the amplifier when it is switched on. The vinyl may be cleaned with a damp (not wet) cloth or brush. The chassis and front panel may be wiped with a cloth or tissue moistened with water and mild detergent or an alcohol based cleaner and then dried. Do not use silicone based polishes on any audio equipment. This material slowly 'creeps' over every surface causing poor contacts, noisy controls etc.

HIWATT AMPLIFICATION INTERNATIONAL

July 1994

DR103 SPECIFICATION

Input line voltages : 100V, 117.5V, 225V, 250V a.c.

Power consumption : 330 Watts (maximum)

Fuse ratings : Mains (100V, 117.5V) - 6.3A (T) slowblow
(225V, 250V) - 3.15A (T) slowblow
H.T. (100V, 117.5V) - 3.15A (T) slowblow
(225V, 250V) - 3.15A (T) slowblow

Valve types : Output valves 4 x matched EL34 (6CA7)
Preamp valves V₁, V₂, V₃, 3 x ECC83 (12AX7)(7025)
Preamp valve V₄ 1 x ECC81 (12AT7)(6201)

Output power : 100W RMS (min) into 8 Ohms

Loudspeaker input impedance : 4 Ohm, 8 Ohm, or 16 Ohm

Dimensions : Width - 640mm Depth - 288mm Height - 269mm

Weight : 20.5Kgs

YOUR HIWATT™ WARRANTY

HIWATT AMPLIFICATION INTERNATIONAL warrants to the purchaser, that this **HIWATT™** product is free from any defects in materials or workmanship under normal use and will provide free service and/or parts exchange within twelve months of the date of purchase. All parts, except electronic valves, are warranted for twelve months from the date of purchase and will be replaced if in the sole judgement of HIWATT AMPLIFICATION INTERNATIONAL, they shall be deemed defective. Electronic valves are warranted for ninety days from date of purchase. This warranty does not apply to equipment showing abuse or damage to parts which in the judgement of HIWATT AMPLIFICATION INTERNATIONAL, are not defective, nor does it extend to any equipment which may have been tampered with, altered, or repaired outside any **HIWATT™** Authorised Service Centre.

When warranty service is required the unit must be shipped to the original place of purchase, freight and insurance paid by the owner.

This warranty becomes effective when the purchaser returns the Warranty Registration Card properly filled out to HIWATT AMPLIFICATION INTERNATIONAL within thirty days of the date of purchase.

THIS WARRANTY DOES NOT AFFECT YOUR STATUTORY RIGHTS

HIWATT AMPLIFICATION INTERNATIONAL,
2-14-26 SHIMOOCHIAI,
SHINJUKU-KU,
TOKYO 161.
JAPAN.

TEL : (81)-3-5996-6469
FAX : (81)-3-3950-1281

HIWATT USA.,
16123 VALERIO STREET,
VAN NUYS,
CALIFORNIA.
91406.
USA.

TEL : (1)-818-988-6795
FAX : (1)-818-988-3094

the AUDIO BROTHERS,
UNIT 8, LITCHBOROUGH INDUSTRIAL ESTATE,
NORTHAMPTON ROAD,
LITCHBOROUGH,
NORTHAMPTONSHIRE.
NN12 8JB.
ENGLAND.

TEL : (44)-1327-830083
FAX : (44)-1327-830083

HIWATT DR103 BACK PANEL

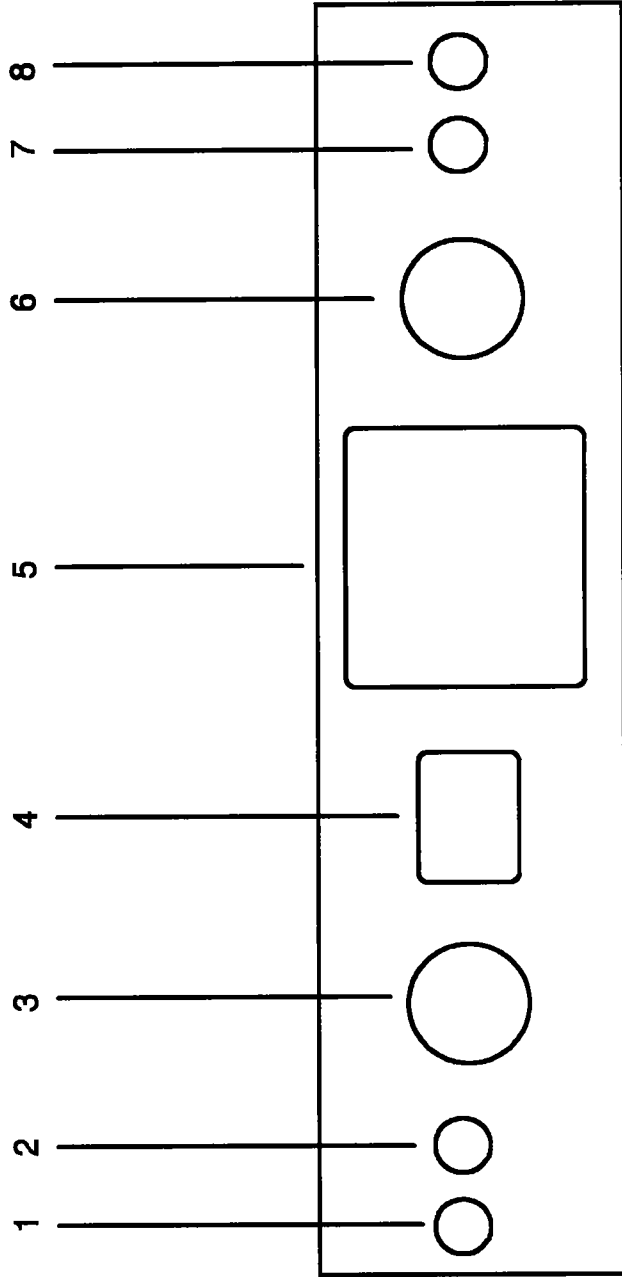

- 1 - Mains Fuse
- 2 - HT Fuse
- 3 - Mains Voltage Selector
- 4 - Mains Inlet Socket
- 5 - Serial Number Plaque
- 6 - Loudspeaker Impedance Selector
- 7 - Loudspeaker Output
- 8 - Loudspeaker Output

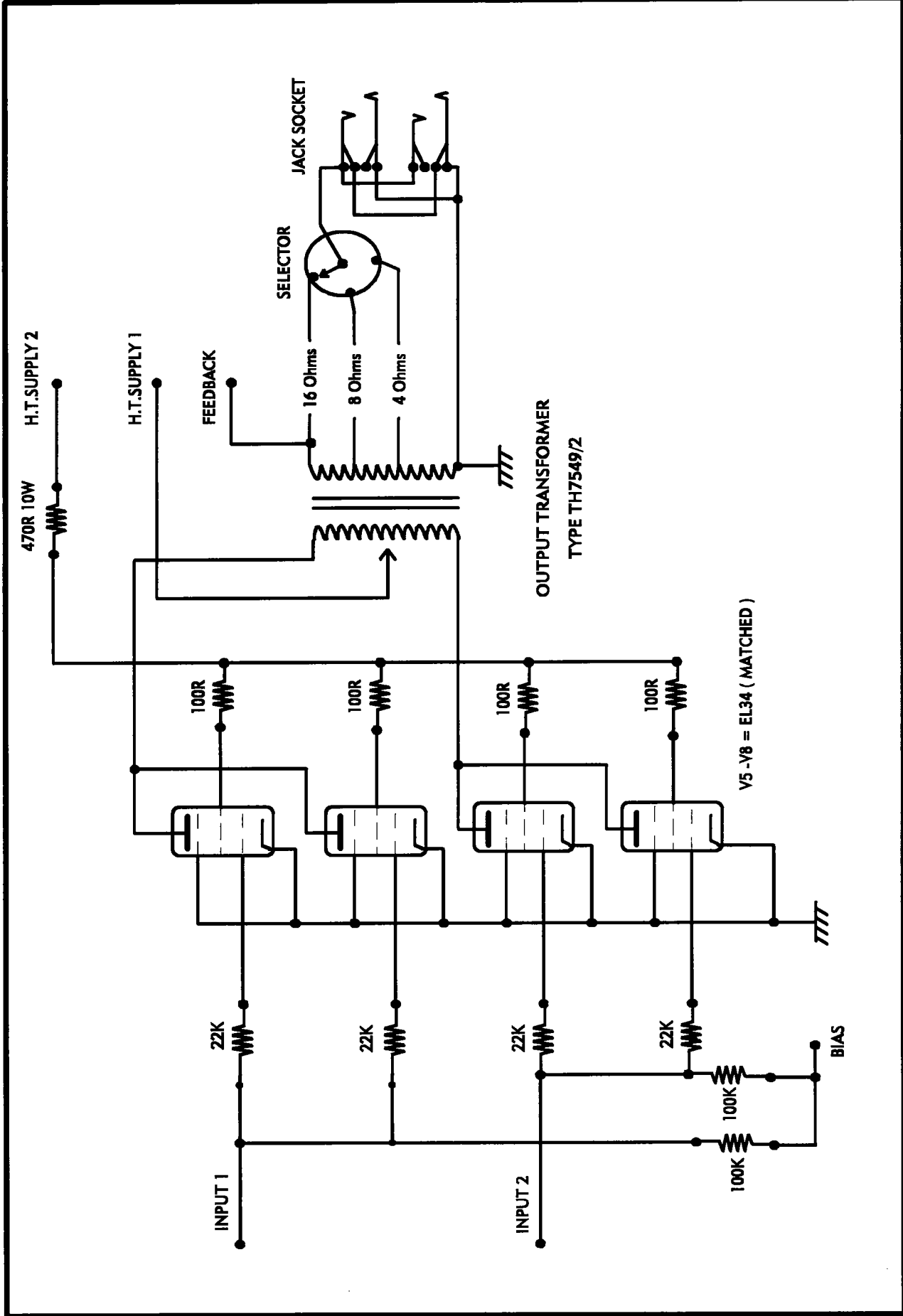

HIWATT DR103 OUTPUT STAGE CIRCUIT DIAGRAM Drawn 25/04/94 Issue 1.

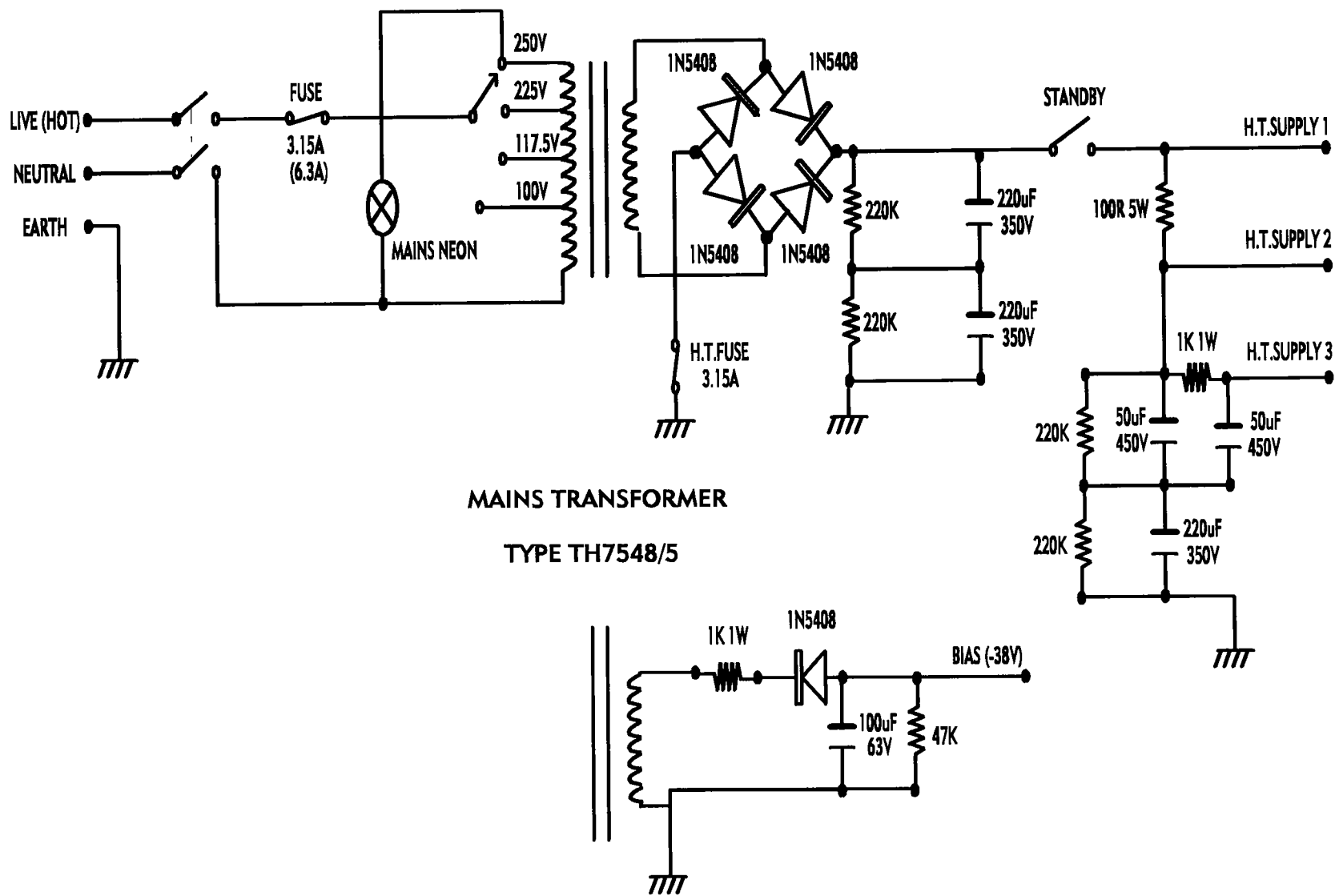

HIWATT DR103 POWER SUPPLY CIRCUIT DIAGRAM

Drawn 22/11/94

Issue 3.