

BASING DIAGRAMS

BOTTOM VIEWS



TIS97

TOP VIEW

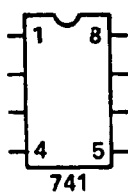

741



2N4303

NOTES:

1. UNLESS OTHERWISE SPECIFIED:
ALL RESISTORS IN OHMS, $\pm 5\%$, 1/2W.
ALL CAPACITORS IN MFD.
2. * Q1 THRU Q4 SELECTED.

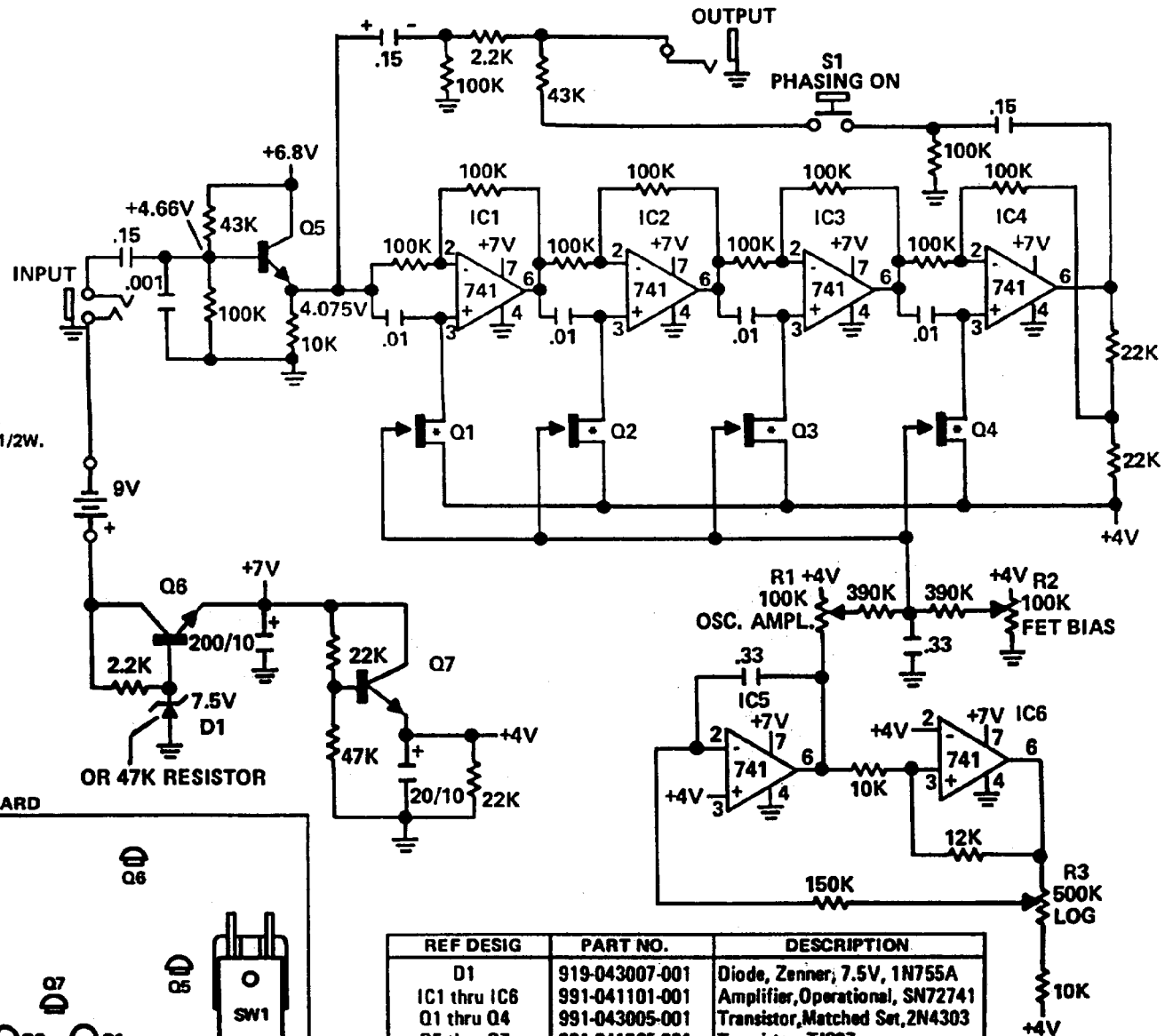

P.C. BOARD

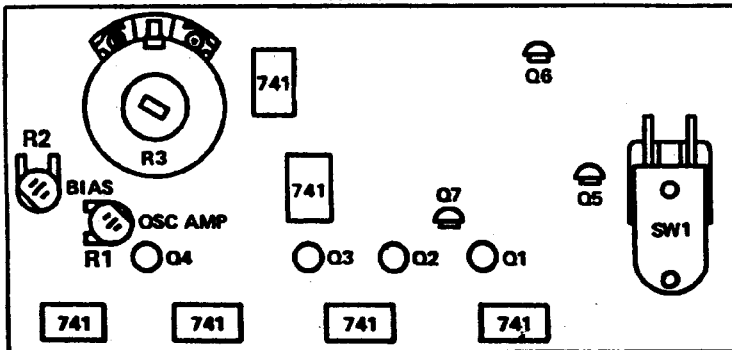

REF DESIG	PART NO.	DESCRIPTION
D1	919-043007-001	Diode, Zener, 7.5V, 1N755A
IC1 thru IC6	991-041101-001	Amplifier, Operational, SN72741
Q1 thru Q4	991-043005-001	Transistor, Matched Set, 2N4303
Q5 thru Q7	991-041265-001	Transistor, TIS97
R1, R2	925-040281-006	Resistor, Variable, 100K
R3	925-043006-001	Resistor, Variable, 500K
S1	960-043004-001	Switch, Push, SPST

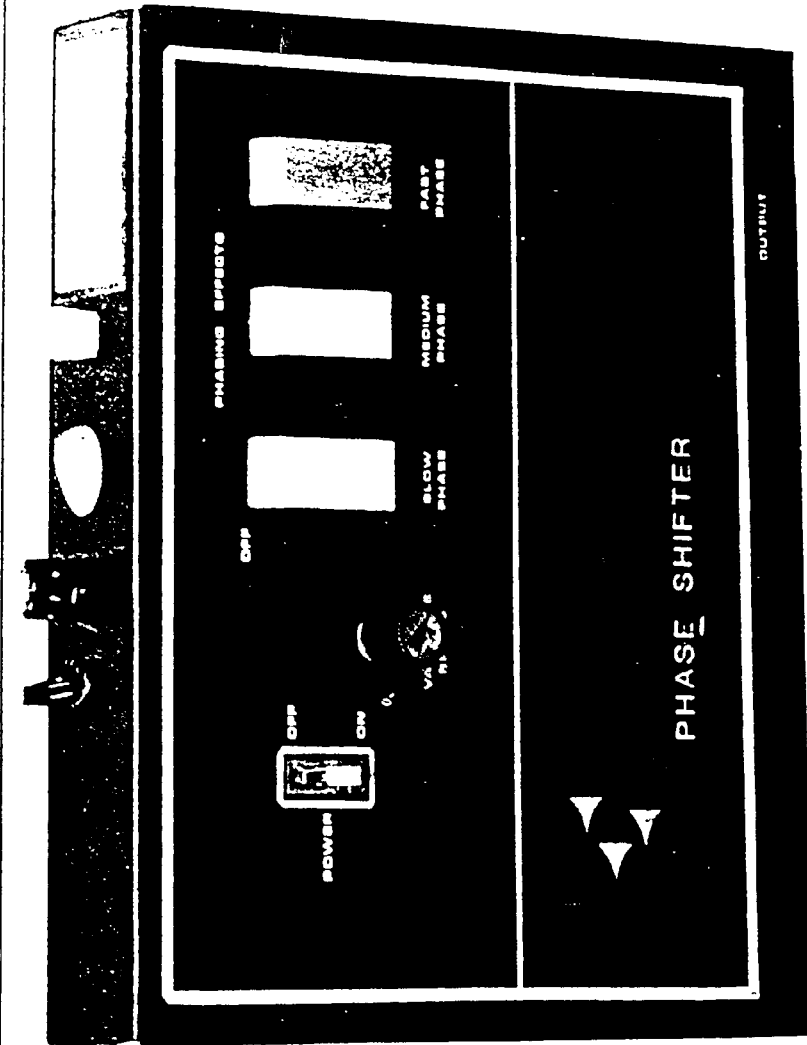

PHASE SHIFTER MODEL PS-1 (VERSION 1)

REF DESIG	PART NO.	DESCRIPTION
D1 thru D4	919-042019-001	Diode, 1N4004
D5, D6	919-043021-001	Diode, Zener, 15V, 1N965
IC1 thru IC4	991-041102-001	IC, MC1458C
Q1 thru Q6	991-043005-001	FET, N-Channel, Matched Set of 6
Q7 thru Q10	991-043011-001	Transistor, 2N3638A
Q11, Q12, Q13	991-041064-001	Transistor, 2N4303
Q14	991-043018-001	FET, N-Channel, 2N4360
R1, R2, R3	925-040281-005	Potentiometer, Trim, 10K
S1	960-010075-001	Switch, Lighted, ON/OFF, Rocker
S1	960-043012-001	Switch, Lighted, ON/OFF, Carling
T1	954-043013-001	Transformer, Power, 115V
T1	954-043013-002	Transformer, Power, 230V
	915-043258-001	Knob, Switch Tab, Orange
	915-043258-002	Knob, Switch Tab, Gold
	915-043258-003	Knob, Switch Tab, Aqua

REF DESIG	PART NO.	DESCRIPTION
D1 thru D4	919-042019-001	Diode, 1N4004
D5, D6	919-043021-001	Diode, Zener, 15V, 1N965
IC1 thru IC4	991-041102-001	IC, MC1458C
Q1 thru Q6	991-043005-001	FET, N-Channel, Matched Set of 6
Q7, Q9	991-043011-001	Transistor, 2N3638A
Q8, Q10	991-041064-001	Transistor, 2N4303
R1, R2, R3	925-040281-005	Potentiometer, Trim, 10K
*R4	925-043000-001	Potentiometer, Audio, 2 Meg
S1	960-043012-001	Switch, Lighted, ON/OFF, Carling
S1	960-010075-001	Switch, Lighted, ON/OFF, Rocker
T1	954-043013-001	Transformer, Power, 110V
T1	954-043013-002	Transformer, Power, 230V
	915-043258-001	Knob, Switch Tab, Orange
	915-043258-002	Knob, Switch Tab, Gold
	915-043258-003	Knob, Switch Tab, Aqua

PHASE SHIFTER MODELS PS-1A AND PS-1B (VERSIONS 2 AND 3)

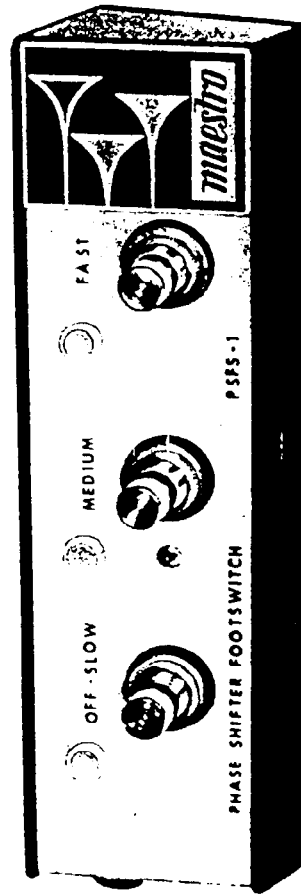

PHASE SHIFTER FOOTSWITCH MODEL PSFS-1

