

**INTERNATIONAL SERIES DESCRIPTION**

The INTERNATIONAL SERIES is a high reliability line of open-frame power supplies designed to operate from the wide range of AC power sources found worldwide.

This feature greatly simplifies your inventory and service considerations by allowing the use of one standard power supply regardless of destination.

Additionally, these models are designed to meet domestic and European regulatory agency requirements.

If you plan to distribute your products worldwide, obtaining necessary agency approvals can be greatly simplified by specifying POWER-ONE, INC. INTERNATIONAL SERIES.



**INTERNATIONAL SERIES  
DC POWER SUPPLIES**

DRAWING NO. 53250 REV G

**SPECIFICATIONS AND APPLICATION DATA**

**VOLTAGE/CURRENT RATING CHART**

MODEL	+5V	+12V	+15V	+24V	+28V	-12V	-15V	CASE
HIGH POWER								
F5-25/0VP-A	Δ 25*							F
F15-15-A		Δ 16 or 15						F
F24-12-A				Δ 12 or 10				F
G5-35/0VP-A	Δ 35*							F
CP197-A	Δ 50*							F

**TRIPLE**

MODEL	+5V	+12V	+24V	-5V	-12V	CASE
HDCC-150W-A	12*	3.4 or 3			3.4 or 3	DCC

**DISK DRIVES**

MODEL	+5V	+12V	+24V	-5V	-12V	CASE
CP340-A	.5/.7Pk*	.9/1.8Pk				340-A
CP510-A	6.0*	2.5/7.5Pk				510-A
CP384-A	9.0*		2/8Pk	1.2 or 1.2		131
CP379-A	6.0*		3.5/8Pk	1.2 or 1.2		131
CP323-A	2.0*	4.0*				N
CP206-A	2.5*		3/3.4Pk	0.5*		CBB
CP205-A	1.0*		1.5/1.7Pk	0.5*		BAA
CP162-A	3.0*		5/6Pk	0.6*		131
CP498-A	6.0*	5/11Pk		.25 or .55		131
CP503-A	6.0*	1.0	2.4/4Pk		1.0	CBB

Δ REFER TO SPECIAL OPERATING NOTE

\* indicates OVP  
— indicates remote sense

released uncontrolled

SPECIFICATIONS SUBJECT TO CHANGE WITHOUT NOTICE

**FEATURES**

- VDE transformer construction
- ±.05% regulation
- T.C. burned-in to MIL-883 Lev. B
- Chassis notched for AC input
- 100/120/220/230-240 VAC
- Industry standard size
- 2 hour burn-in period
- Remote sense - most outputs
- UL recognized/CSA certified
- OVP on 5V outputs
- Full-rated to 50°C
- Foldback/current limit

**SPECIFICATIONS**

- AC INPUT:** 100/120/220/230-240 VAC\*\* +10%, -13%, 47-63 Hz. (Derate output current 10% for 50 Hz operation.) See AC connection table under APPLICATION NOTES for jumper information. Fuse information is next to outline and mounting drawings.
- DC INPUT:** See Voltage/Current Rating Chart. Adjustment range ±5% minimum. (+5 non-adjustable on CP340-A model.)
- LINE REGULATION:** ±.05% for a 10% line change (±.01% for F,G & CP197-A).
- LOAD REGULATION:** ±.05% for a 50% line change (±.02% for F,G & CP197-A).
- OUTPUT RIPPLE:** 2V to 15V units: 5.0mV PK-PK maximum.  
20V to 200V units: .02% PK-PK maximum.
- TRANSIENT RESPONSE:** ≤50us for a 50% load change.
- SHORT CIRCUIT AND OVERLOAD PROTECTION:** Automatic current limit/foldback.
- OVERVOLTAGE PROTECTION:** Built-in on all 5V outputs. Set at 6.2V ±.4V. Other models use optional overvoltage protection.
- REMOTE SENSING:** Provided on most models, open sense lead protection built-in.
- STABILITY:** ±0.3% for 24 hour period after 1 hour warm-up.
- TEMPERATURE RATING:** 0°C to 50°C full-rated, derated linearly to 40% at 70°C. 12 CFM forced air cooling required to meet IEC 380/950 above 80% of total rated output power.
- TEMPERATURE COEFFICIENT:** ±.03%/°C maximum.
- EFFICIENCY:** 5V units: 45%  
(typical) 12V and 15V units: 55%  
20V and 24V units: 60%
- VIBRATION:** Per MIL-STD-810C, Method 514, Procedure X, CAT G-1
- SHOCK:** Per MIL-STD-810C, Method 516, Procedure V
- \*\*Tolerance for 230VAC operation is +15%, -10%

**WARRANTY**

POWER-ONE, INC. warrants each power supply of its manufacture that does not perform to published specifications, as a result of defective materials or workmanship, for a period of two (2) full years from the date of original delivery.

POWER-ONE, INC. assumes no liabilities for the consequential damages of any kind through the use or misuse of its products by the purchaser or others. No other obligations or liabilities are expressed or implied.

**PRODUCTS RETURNED FOR REPAIR**

Please follow this procedure when returning products for servicing:

- Contact Power-One's Customer Service Department for authorization to return products:  
POWER-ONE, INC. PHONE: (805) 987-8741  
740 Calle Plano (800) 678-9445  
Camarillo, CA 93012 FAX: (805) 388-0476  
USA TWX: 910-336-1297
- A Returned Material Authorization (RMA) will be issued and must appear on all shipping documents and containers.
- Products must be returned freight pre-paid. Products returned freight collect or without an RMA number will be rejected and returned freight collect.

**REMOTE SENSE**

Remote sense terminals may be used to compensate for output line losses and provide for a remote point of regulation. Figure 1 shows the proper termination for a power supply with remote sensing.

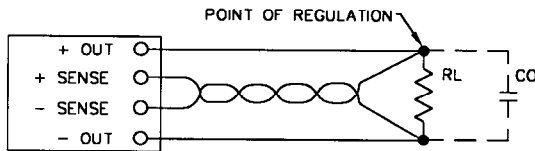

FIGURE 1

Load lines must be sized to prevent an excessive voltage drop from the output to the load. Since the point of regulation is at the load, the power supply must compensate for line losses. Excessive load line losses may affect current limiting, AC line dropout point and OVP margin (if applicable).

Leads should be sized to drop no more than 0.5V - the less the better. Use of a twisted pair or shielded pair for the sense lines is recommended for noise immunity. In problem applications, the use of a small AC decoupling capacitor (.1 to 10uF) across the sense terminals is highly recommended. In some applications there may be a tendency for the power supply to oscillate due to additional phase shift caused by the series resistance and inductance in the load leads. The addition of capacitor Co will reduce output impedance and provide stability. The recommended value of Co is 100uF per ampere of 50uF per foot and can be the sum of the distributed decoupling capacitors found in most systems.

All Power-One supplies have open sense lead protection to protect the load from an overvoltage condition if the sense leads are removed. There is no need to strap the sense terminals to the output terminals in the local sense mode.

**OVERVOLTAGE PROTECTION (OVP)**

An overvoltage protection circuit, commonly referred to as a crowbar, is used to prevent damage to voltage sensitive loads such as TTL logic. Trip point of the OVP is usually set at 115% - 135% of the output voltage. The OVP will short the output terminals upon sensing a fault condition. The primary fuse of the supply will blow if the supply is not foldback current limited. Nuisance tripping of the OVP is a common problem. Noise from input line spikes or load noise can cause an OVP to fire. The INTERNATIONAL SERIES has OVP noise filtering to prevent nuisance tripping and reduce transformer interwinding capacitance to minimize input line susceptibility.

**COMMON-MODE LATCH UP**

In certain instances dual power supplies can exhibit a problem known as common-mode latch up. This occurs when the positive supply comes up first and forces a reverse bias condition on the negative supply. The negative supply latches up in a current limit condition. Power-One has incorporated a unique anti-latch circuit into every dual power supply in the INTERNATIONAL SERIES which will minimize this problem.

**EMI/RFI**

These linear power supplies have inherently low conducted and radiated noise levels. For most system applications they will meet the requirements of FCC Docket 20780 for Class A equipment and VDE 0871 for Class A equipment without additional noise filtering. For special applications consult factory.

**COOLING**

Convection cooling is adequate where non-restricted air flow is available. When operating in a confined area, moving air or conduction cooling is recommended.

**SAFETY SPECIFICATIONS**

The INTERNATIONAL SERIES power supplies were designed to meet or exceed requirements for the following specifications: IEC 380, IEC 435, VDE 0730 Part 2, VDE 0804, ECMA-57, CEE 10 Part 2P, UL 1012, CSA 22.2 No. 143, CSA 22.2 No. 154. Specifically field terminal to terminal spacing is 5.25 mm with 9.0 mm creepage to other metal, leakage current is less than 5.0uA and dielectric withstanding voltages are 3750 VAC input to chassis, 3750 VAC input to output and 300 VDC output to chassis.

**GROUNDING**

Grounding considerations in designing a power distribution system are often overlooked but can have a significant impact on overall system performance. A single point system ground should be employed where possible to eliminate ground loops and improve regulation.

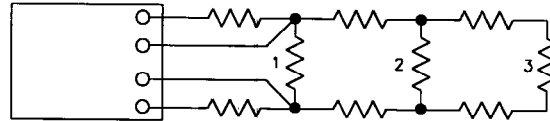

FIGURE 2

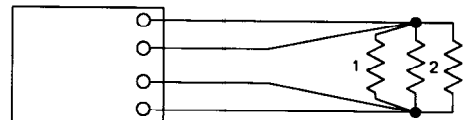

FIGURE 3

Figure 2 shows a simple but undesirable connection scheme. Regulation at loads 2 and 3 becomes progressively worse due to voltage drops in the finite wire resistance between loads. Figure 3 shows an improved connection system in which regulation is maintained at all three loads because wire losses are not cumulative.

**AC INPUT CONSIDERATIONS**

Almost all power supplies use a capacitive input filter that draws current only at the peaks of the AC input voltage. The peak to RMS ratio can be very high, typically 3 to 1. When a supply is turned on, the input capacitor has a very low impedance and draws an initially high surge current until it charges to its nominal voltage. The input surge current can be as high as 20 times the rated input current and lasts for several cycles of the AC input.

**AC CONNECTION AND FUSING\***

The five wire input to the INTERNATIONAL SERIES provides four voltage ranges: 100/120/220/230-240\*\* +10%, -13%. See chassis AC connection table (Figure 4) for the jumpering requirements. For convenience the jumper sequence from the Hi-Vol series is retained. Extended low line tolerance provides additional drop out margin in areas where line voltages are marginal. Inputs must be fused.

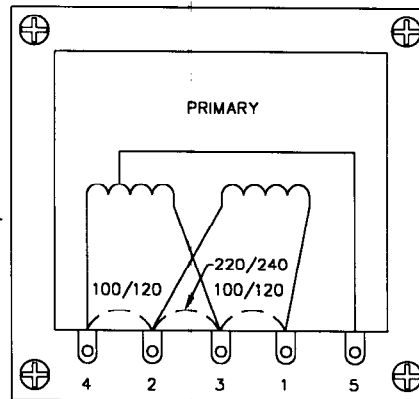

FIGURE 4

AC INPUT, 47-63 HZ				
FOR USE AT	100 VAC	120 VAC	220 VAC	230/240 VAC
JUMPER	1&3 2&4	1&3 2&4	2&3	2&3
APPLY AC	1&5	4&1	1&5	4&1

NOTE: This product is a Class 1 power supply and requires the chassis to be connected to earth ground at end application.

\*NOTE: Use 700°C iron for soldering input connections. Varnish acts as flux and is solder strippable.

\*\*NOTE: Tolerance for 230VAC operation is +15%, -10%.

**SPECIAL OPERATING NOTE:**

**MASTER/SLAVE USAGE:**

General Notes - In Master/Slave connection, the master unit will control up to 5 slaves; however, in an over current condition, each supply will operate its own current limit/foldback circuit for protection. The sharing of current at full load is within  $\pm 10\%$ .

OVP - if any supply senses an over voltage condition, it will fire and shut off drive to all units. No power is consumed in the OVP mode and OVP may be reset by removal of input power or the momentary grounding of inhibit (to - out).

Remote program, remote V. adj, remote OVP and inhibit all may be connected to the master and will operate identically to a single unit (inhibit is 30mA per unit).

Individual fusing is recommended for each supply. In the case of any blown input fuse, the output voltage will be reduced to  $< 3V$  with a nominal load.

**SLAVE CONFIGURATION:**

To make any unit a slave, adjust R12 (R16) (V. ADJ.) fully counter-clockwise.

**MASTER CONFIGURATION:**

- 1) Connect all master and slave + and - output terminals to the load with separate equal length wires of adequate size.
- 2) Fuse each power supply individually to the AC power input.
- 3) Connect a #20GA wire from "Ext.Dr." on the master to the "Ext.Dr." on all the slaves (up to 5 slaves).
- 4) Apply input power and set master to desired voltage.

**REMOTE PROGRAM:**

Remove R21 (R20). Install program resistors between power supply "+ sense" and users "+ load" terminals. Programming is approximately 500 $\Omega$ /volt. Use "Make-Before Break" switch or equivalent.

**REMOTE V. ADJ:**

- 1) Cut open-lead protection resistor R21 (R20) out of the circuit board.
- 2) Connect remote 1K pot from power supply "+ sense" terminal to users "+ load" terminal. (Power supply will then sense to "+ load" terminal and be remotely adjustable).
- 3) Adjust R12 (R16) on circuit board fully counter-clockwise.
- 4) Adjust remote pot to desired voltage.

**ADJUSTABLE OVP:**

To set OVP at desired voltage:

- A) Set R16 to max. (fully clockwise).
- B) Set supply to desired trigger voltage.
- C) Reduce R16 resistance until OVP fires.
- D) Ground inhibit to reset OVP, then recheck OVP trigger point.
- E) Reset supply voltage to normal output.

NOTE: ( ) DENOTES DESIGNATIONS USED FOR F15-15-A AND F24-12-A. THE OTHER DESIGNATIONS ARE USED ON F5-25/OVP-A, G5-35/OVP-A, AND CP197-A MODELS.

OPERATING NOTES ABOVE APPLY TO F, G AND CP197-A UNITS ONLY.

**SERIES OPERATION**

Any Power-One supply may be operated in series with any other Power-One power supply. The only restriction is that the current required by load 3 must be less than half the current rating of the lesser unit.

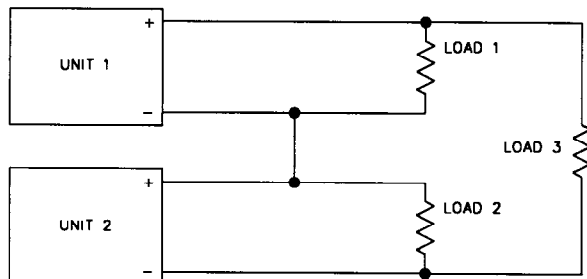

**PARALLEL OPERATION**

Any 2 or more Power-One units of the same voltage may be operated in parallel. The following rules apply:

- 1) The units must be set to the same voltage within .2%.
- 2) Local sense must be used.
- 3) Units may be of different current ratings.
- 4) Proper hook-up wire must be utilized.

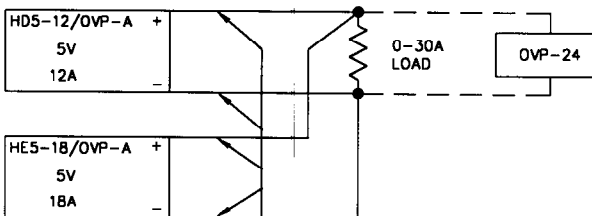

Calculate wire size and length to drop 25, 50, or 100 mV on 5, 15, or 24V units respectively, at unit rated current.

**F CASE**

WT. 19LBS.

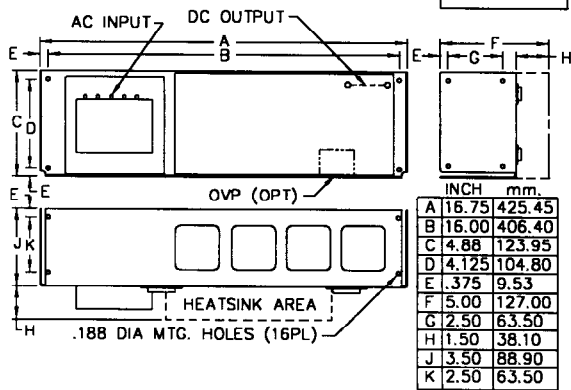

FOR FUSING RECOMMENDATION, REFER TO CHASSIS SILKSCREEN.

**DCC CASE**

WT. 12LBS.

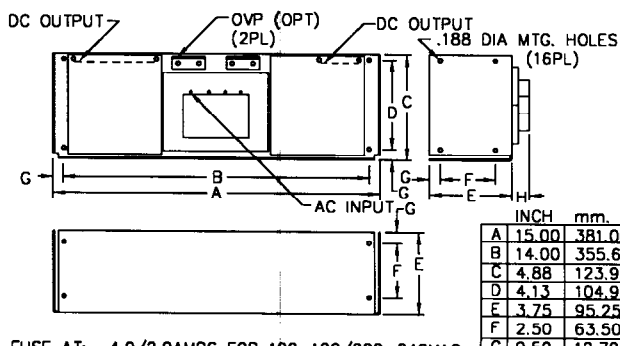

FUSE AT: 4.0/2.0AMPS FOR 100-120/220-240VAC

**CP340-A CASE**  
WT. 2 LBS.

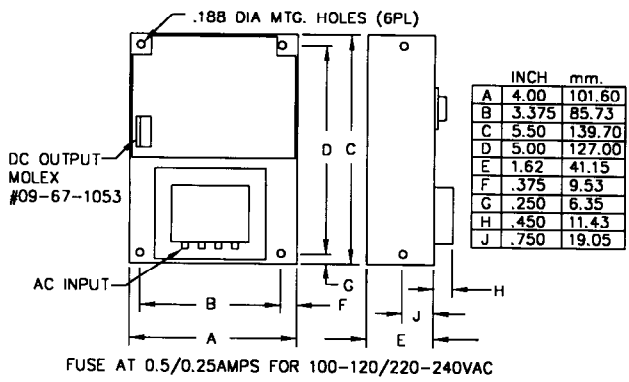

**CP510-A CASE**  
WT. 7.5 LBS.

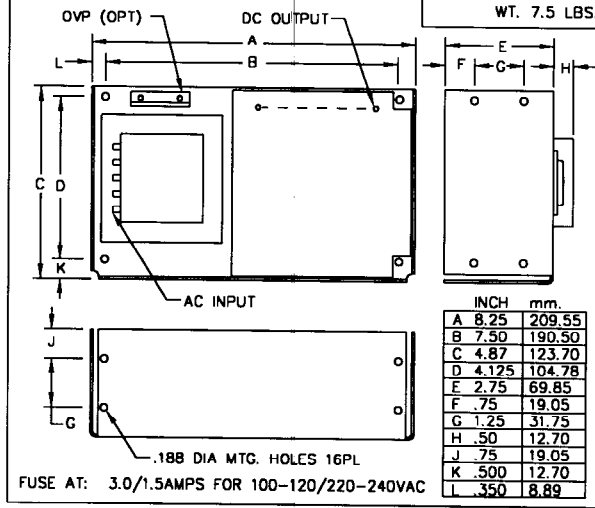

**131 CASE**  
WT. 9 LBS.

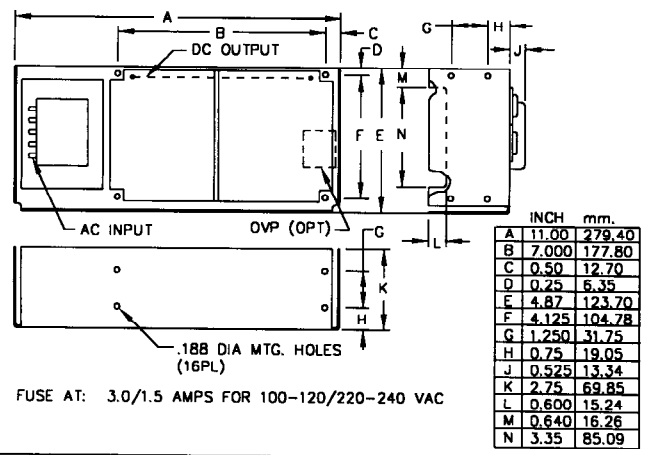

**N CASE**  
WT. 6 LBS.

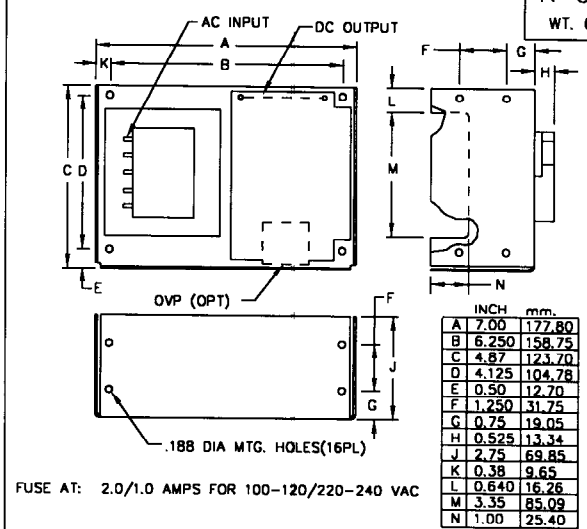

**CBB CASE**  
WT. 8 LBS.

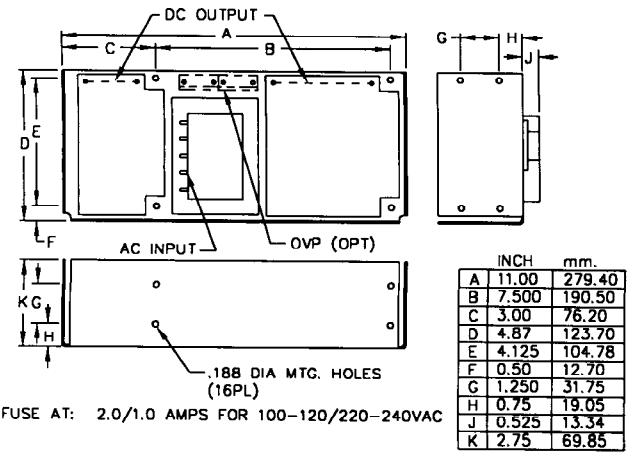

**BAA CASE**  
WT. 5 LBS.

