

**THE SL 6000 E SERIES  
STEREO VIDEO SYSTEM  
OPERATIONAL GUIDE**

**VERSION 1.6F**

## SECTION 2

# ROUTING AND SIGNAL FLOW

### INTRODUCTION

The SSL is a highly flexible mixing system and as such it is virtually impossible to cover all these routing configurations on one flow diagram. The solution to this problem is to break the console down into sections and look at each one individually, examining each routing configuration in detail.

So this is the order in which we will tackle, in more detail, the various operating modes:

1. The SL 611-V I/O module and the main STATUS buttons
2. Audio Subgrouping facilities
3. Signal Processing within the SL 611-V I/O module
4. The SL 688-V Mix Matrix Panel

The applications section illustrates all these routing configurations by incorporating them in detailed examples of a session. You may find that you get a clearer understanding of the various modes by reading through the applications section first. It's up to you.

The signal routing through the Stereo SL 611-S module is relatively simple and is unaffected by the Master STATUS buttons. Section 4 covers routing within the Stereo module in sufficient detail so it has not been included in this section.

A few points to bear in mind:

The Master Status buttons only affect the SL611V I/O modules. The SL 611-S Stereo modules, the SL 651-V Master Facilities Module and the SL 688-V Mix Matrix Panel work independently of the STATUS buttons.

In most studios the RECORD status button is connected to the multitrack Sync/Repro Switching so that whenever the console is in the RECORD or MIX/RECORD status the multitrack will automatically switch to Sync.

# THE SL611V I/O MODULE AND THE STATUS BUTTONS

Always remember that there are two separate audio paths through the SL611V I/O module. Each path has an INPUT, a controlling FADER and an OUTPUT section. One path is called the CHANNEL path and the other is called the MONITOR path. The two paths each have their own INPUT:

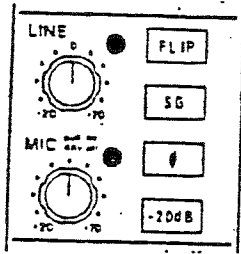

## CHANNEL INPUT SECTION

Select from:

- a) MIC b) LINE
- c) SUBGROUP

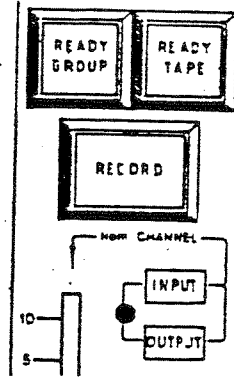

## MONITOR INPUT SECTION

Select from:

- a) TAPE MON b) GROUP MON c) CH INPUT
- d) pre CH VCA FADER e) post CH VCA FADER

and depending on the master STATUS buttons and local FLOAT control, they may be controlled by either fader:

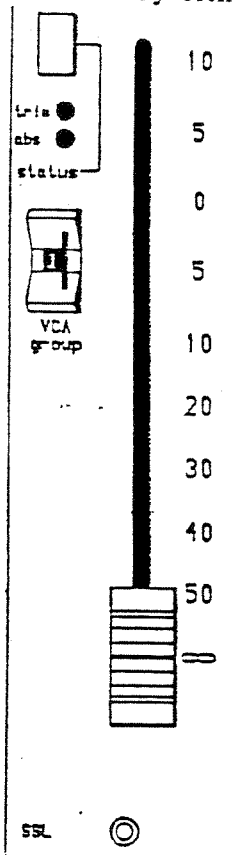

LARGE VCA FADER

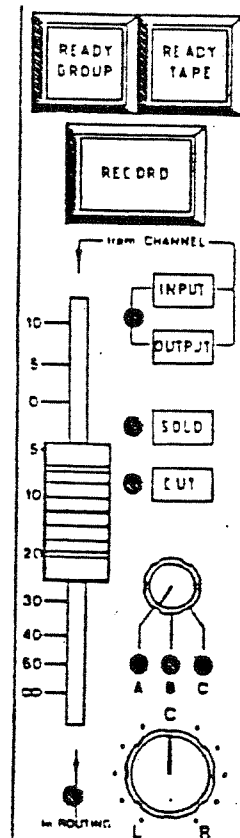

SMALL FADER

and they may have one of two possible destinations:

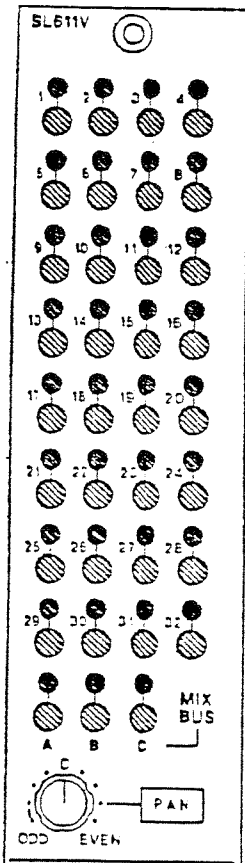

ROUTING MATRIX

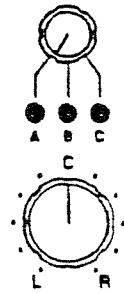

A, B, C STEREO MIX BUS SELECTOR

The STATUS and signal flow diagrams that follow show routing for each mode. There are three possible input selections for the Channel input and five possible input selections for the Monitor input. The highlighted input source is the one which is selected by the master logic. Any of the other sources may be selected by operating local controls, which override the master selection.

The mic input is sent via the Large fader to the multitrack routing matrix, and the Tape return (or Group send) is sent via the small fader to the stereo mix bus via the A, B, C Mix Bus Selector.

This mode of operation is usually selected when multiple inputs are to be sent to the Multitrack via the Large fader and monitored on the small fader through the main programme output. The multitrack ATR is set to Sync.

RECORD + VCA TO MONITOR

The console and the multitrack remain in RECORD status, but the Small Fader is placed in the Channel signal path and the Large Fader is placed in the Monitor signal path.

This mode is preferred to the RECORD mode by many engineers who use the small fader to send channels to the multitrack machine thus providing the "cleanest" possible signal path for track laying. Note that as the small fader is now in the channel signal path the INPUT and OUTPUT buttons next to the small fader (which normally allow the small fader to pick up pre and post channel fader signals) will not be operational, so preventing a routing configuration which would cause a feedback loop (ie. the post fader signal being routed back to the fader input). These buttons are described in more detail on page 3-24.

This status allows the Large fader to be used for monitor mixing the multitrack returns (and/or Group sends). It is more convenient to monitor mix on the larger faders plus they can be automated if required for quick monitor mixes at the end of a session.

# MASTER STATUS

CH INPUT FLIP	TO MONITOR	STATUS LOCK
<b>RECORD</b>	REPLAY	<b>MIX</b>

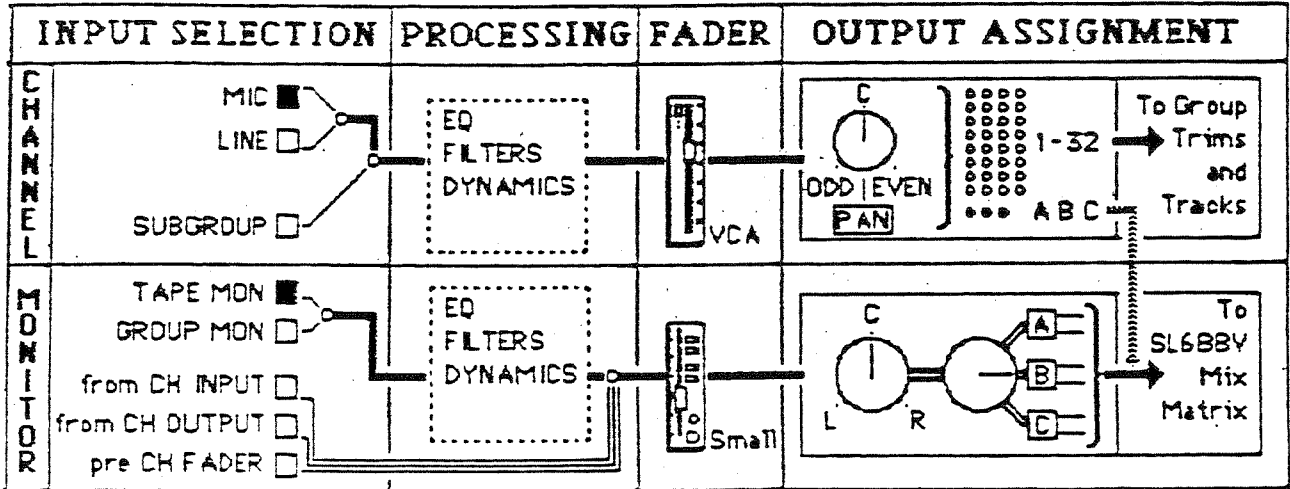

# MASTER STATUS

MASTER CH INPUT FLIP	<b>VCA's TO MONITOR</b>	STATUS LOCK
<b>RECORD</b>	REPLAY	<b>MIX</b>

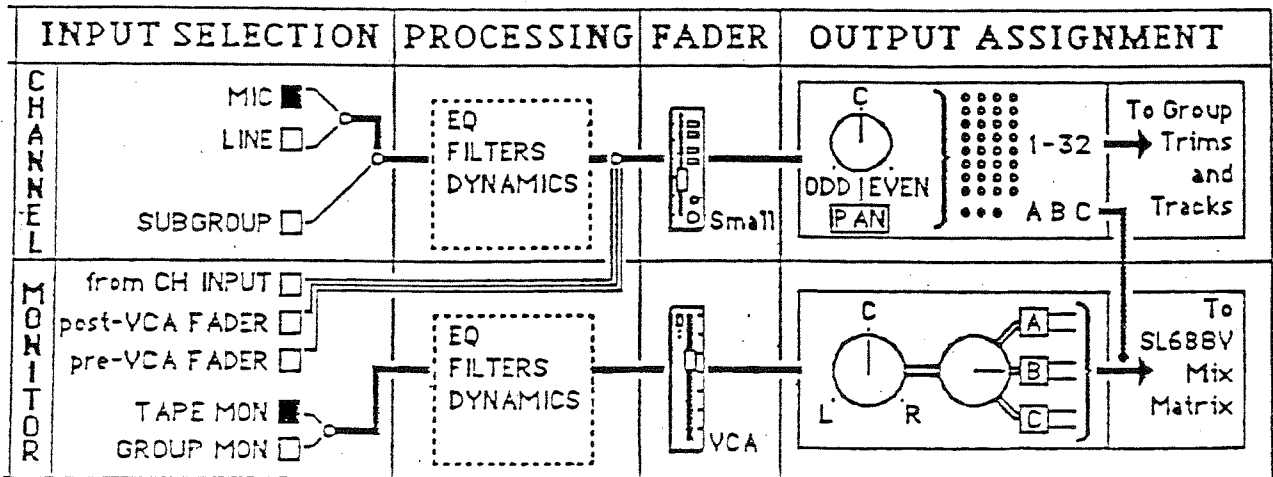

The line input is sent via the Large fader to the A, B, C Stereo Mix Bus Selector. The small fader can now pick up any of the five desired input sources and send them to the Routing Matrix. The Multitrack ATR is set to Repro.

The obvious mode for mixing! The small fader can be used to send additional line inputs (or mic inputs if SSL external mic preamps are used) to the stereo mix buses via the A, B and C switches found in the routing matrix. Hence a 40 module console fitted with 40 I/O modules can route 80 inputs via faders to the Mix buses. From the diagram it can be seen that the Tape Monitor inputs (patch row K) are automatically selected by the master logic if neither of the READY TAPE or READY GROUP buttons are on, hence patch external inputs into these jacks.

By pushing the INPUT and OUTPUT buttons on the Monitor input section a feed from the channel can be sent via the small fader to the routing matrix and then to an effects device (see page 3-24). The small fader then becomes an additional effects send.

This facility can also be used to provide additional clean feeds from the console and is discussed in more detail in the applications section relating to Broadcasters.

### MIX + MASTER CHANNEL INPUT FLIP

The console remains in MIX status, but the line inputs to the channel signal path are replaced with microphone inputs. It effectively FLIPS all the channel inputs from mic to line.

This is the basic live broadcast mode. In this instance the majority of sources will be microphones so the console is instantly configured to mix microphones down to the main Programme output via the A, B, C Stereo Mix Buses (which can be used as mix minus feeds). Individual line level sources are easily catered for by flipping that channels' input with the channel FLIP button.

The Small faders function as in the MIX mode but in many cases, SSL external mic preamps are used to provide additional mic inputs to the programme feed (with a 56 module console this allows 112 mics to be mixed down simultaneously!).

# MASTER STATUS

CH INPUT FLIP	TO MONITOR	STATUS LOCK
RECORD	REPLAY	MIX

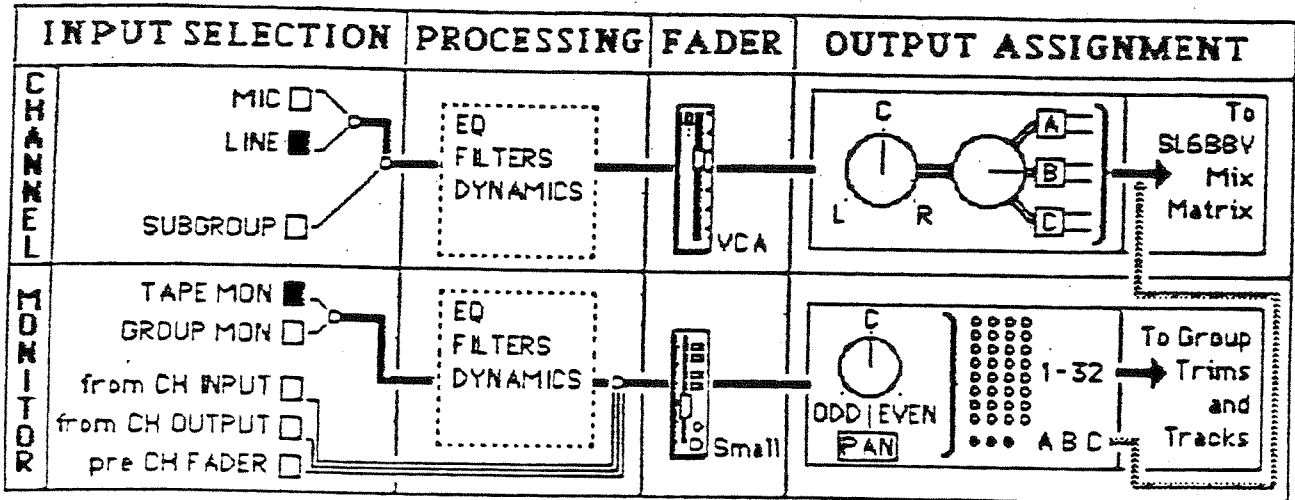

# MASTER STATUS

MASTER CH INPUT FLIP	VCA's TO MONITOR	STATUS LOCK
RECORD	REPLAY	MIX

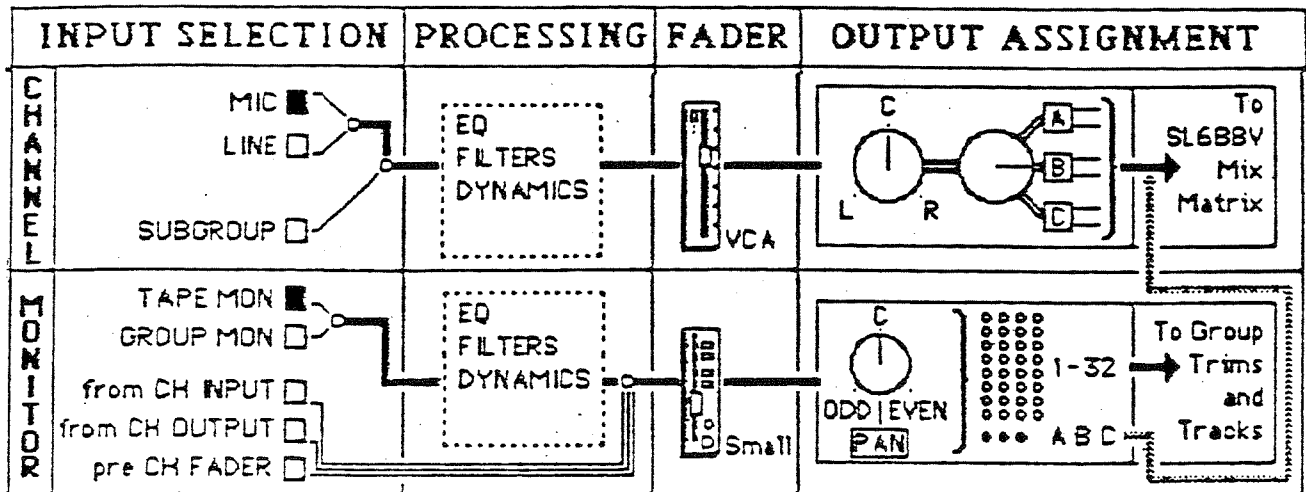

The console remains in the MIX mode, but when a READY button is selected on any module that module assumes the RECORD status.

This is the Overdub mode used when initial tracks have been laid in the RECORD mode and individual tracks are now being added one at a time. In posting applications it makes a great deal of sense to always work in this mode whilst laying tracks as the process usually involves recording single tracks one after another. It allows a mix to be built up whilst laying tracks. As each track is recorded the READY button is released and the module behaves as in MIX mode. Gradually the recorded tracks are brought up to form a mix on the Large faders one by one.

Eg. To overdub onto track 16.

There are two ways to do this:

1. Hit READY GROUP (and/or READY TAPE) to put module 16 into the RECORD STATUS.
2. Mix all the other channels together using the Large faders, as a monitor mix.
3. Bring the mic into channel 16. As this module is in the RECORD mode the mic will be fed via the Large fader to the multitrack routing matrix. Pressing the DIRECT button on the module will bypass the matrix and feed the mic directly to multitrack group 16. The small fader can be used to monitor the send (and/or return) mixed in with the other channels.

The module RECORD button can be used to drop the machine into record. Remember also that as the master RECORD status button has been pressed so the multitrack ATR will automatically have been switched to sync.

The other way of recording this way uses a channel outside modules 1 to 24 to feed the multitrack. The method above is fine for some applications but the mic will have to be patched to follow the module which is switched to the RECORD mode. Laying a single mic (or cart etc.) to many tracks becomes a pain due to the fact that it has to be repatched each time. A much simpler way is:

1. Use channel 25 as the source. So plug the mic into channel 25 mic input and FLIP the input to Mic. This module is in the MIX mode as no READY buttons are pressed. FLOAT the channel so the mic is fed to the routing matrix via the large fader. Route the mic to group 16 by selecting 16 on module 25's routing matrix.
2. Hit READY GROUP (and/or READY TAPE) to put module 16 into the RECORD STATUS.

3. Mix all the other channels together using the Large faders, as a monitor mix.
4. Monitor the Group send (and/or the Tape return) on module 16's small fader and use module 16's RECORD button to drop the track into record.
5. Now to record the same mic onto track 17 simply deselect 16 and select 17 on module 25's routing matrix. Deselect module 16's READY GROUP (and/or READY TAPE) button. Adjust the Large fader to mix in the previously recorded track 16 and then put module 17 in the RECORD mode by selecting the READY GROUP (and/or READY TAPE button) and start all over again.

As with many things in life this is easier done than said and you will probably need to go over this a couple of times before it starts making sense. If it still doesn't make sense then perhaps you should turn to page one and switch on the answerphone for a couple of hours.

#### REPLAY STATUS (not shown)

The current console status is put on "standby" and the Tape returns are routed to the monitor faders. This allows a quick replay of the tape without disrupting the console setup. The multitrack ATR is switched to Replay.

This status is used during track laying. For example after operating in the RECORD status whilst laying tracks the time comes when a quick monitor mix is required. This could be accomplished in the RECORD mode by deselecting all the READY GROUP buttons, manually switching the multitrack machine to Replay and mixing down the monitor inputs to the main output buses and then on to a stereo ATR. The REPLAY status does all this with one button. All the READY GROUP selections are temporarily disabled and all the monitor inputs look at the multitrack returns off the replay head.

Deselecting the REPLAY status and reselecting the RECORD status will return all the previous READY TAPE and READY GROUP button selections and the multitrack is switched back to Sync ready for more recording.

## THE FLOAT BUTTON

In addition to the main status buttons there is one additional button, located on the SL611V I/O module which affects signal flow through the module. The FLOAT button actually breaks away ("floats") whichever signal was routed to the main stereo output buses. It then sends this signal up to the module routing matrix. At the same time the signal that was feeding the routing matrix is disabled.

This has two uses depending on the STATUS of the console:

In RECORD status you will remember that the Large VCA Fader is feeding signals up to the multitrack via the routing matrix. The small fader is monitoring the Groups/Track Returns onto the main stereo output buses. If the FLOAT button is operated the small fader will now float off the main stereo outputs and feed the routing matrix. This mode, known as "Float in Record", allows track bouncing to be performed quickly and easily, directly from the monitor mix. The track or tracks on which the bounce is being recorded may be monitored by pressing their associated READY GROUP or READY TAPE buttons.

In the MIX status the Large VCA Fader feeds the output buses and the Small Fader feeds the routing. Hence pressing FLOAT disables the monitor fader, breaks away the Large VCA Fader carrying the channel signal, from the output busses, and sends it to the routing matrix. This mode known as "Float in Mix" and allows patchfree creation of audio subgroups. The bus or buses to which the channels have been routed are returned to the mix by pressing the SUBGROUP buttons on their associated I/O modules, which then serve as subgroup masters. In MIX + RECORD status the float button is quite often used to send sources, plugged into the channel inputs, straight up to the routing matrix and to the multitrack. These sends are then monitored on the appropriate module by selecting that module's READY GROUP or READY TAPE button, hence putting the module into the RECORD mode.

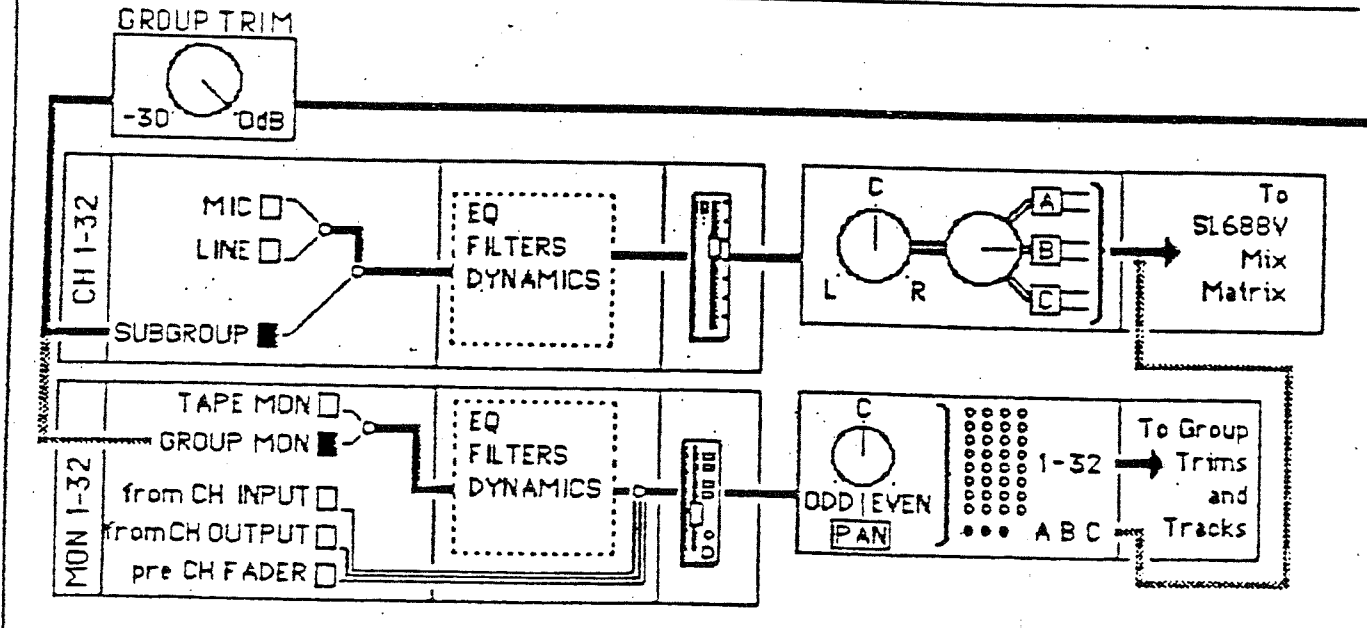
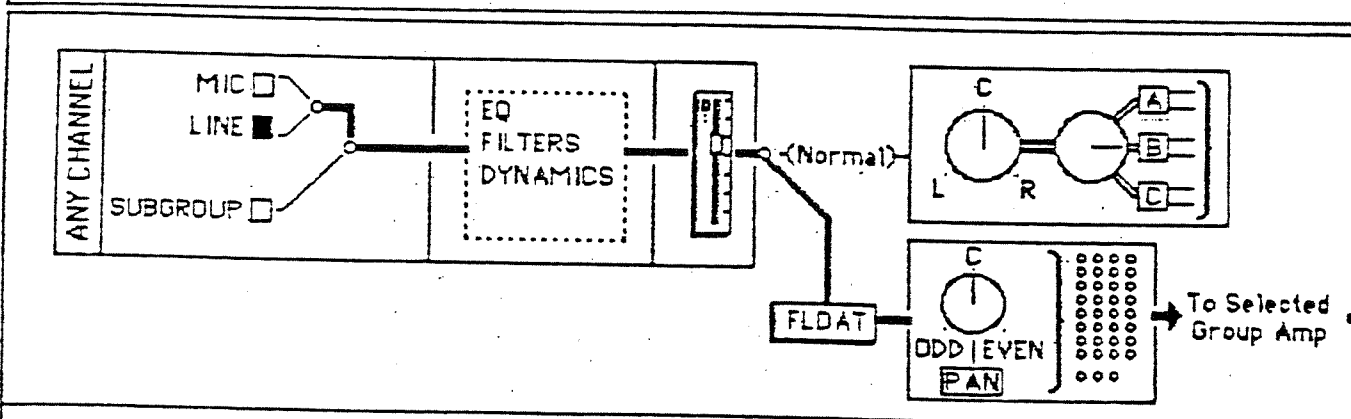
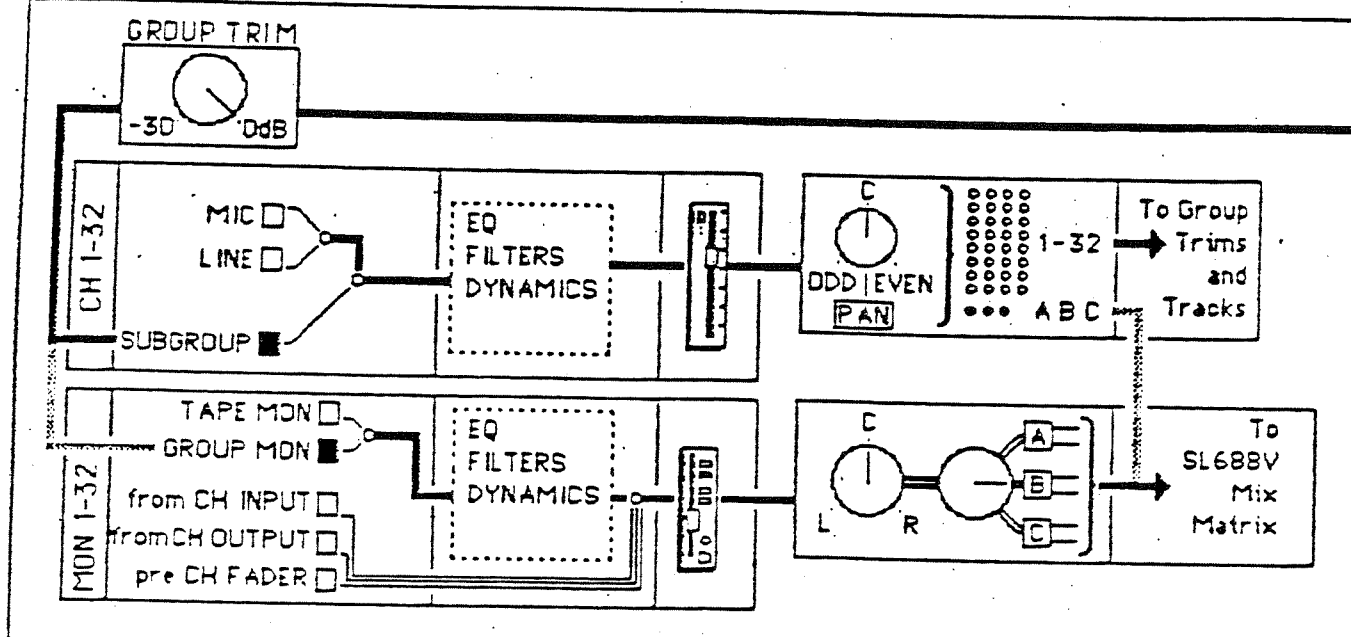
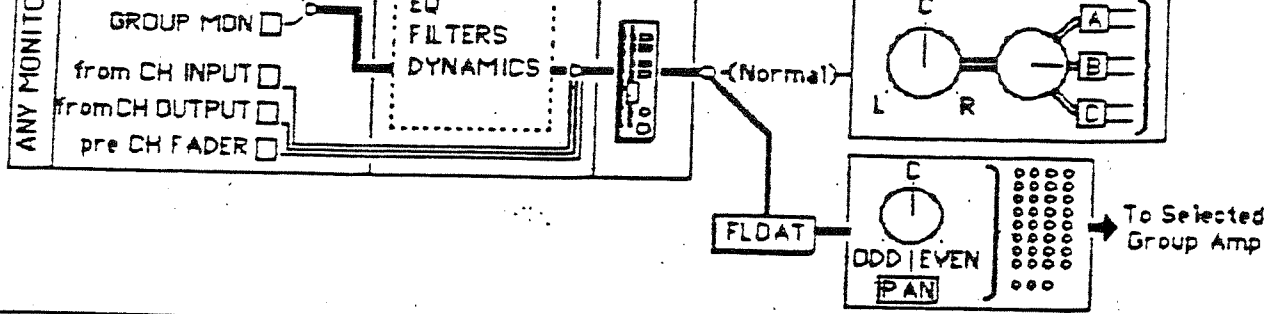

## AUDIO SUBGROUPING FACILITIES

The design of the system allows as many subgroups as are required to be configured at the push of a button. The flexibility of the routing enables the engineer to use both Monitor and Channel signal paths as subgroups when mixing.

The creation of a subgroup, whilst in the RECORD status, is obviously a matter of routing the source channels to the appropriate track of the multitrack machine and monitoring these groups using the monitor fader.

When in the MIX status there are four possible ways to create audio subgroups:

### *LARGE FADERS TO LARGE FADERS*

Discussed briefly on the previous page this involves the FLOAT button. Any of the first 32 modules (as there are only 32 routing buttons) may be selected as subgroup masters by pressing the channel SUBGROUP button. Other channels may now be routed to that subgroup by floating them off the main output buses and using the routing matrix at the top of the I/O module to send these signals to the group of the selected subgroup (ie. If channel 25 was the subgroup, it's channel input would have the SUBGROUP button depressed. Channels 1 to 8 could be routed to this subgroup by floating them and selecting 25 on their routing matrices).

### *LARGE FADERS TO SMALL FADERS*

In the example above it is possible to make the Monitor path of module 25 the subgroup master if we wished, rather than the channel path. In this case, instead of selecting the SUBGROUP button on the channel input, the READY GROUP button is pressed. This now feeds group 25 signal to the Small Monitor fader. This fader, in the MIX status, feeds the routing matrix and can be sent directly to the main output buses by selecting the A, B or C buttons located in the routing matrix itself.

### *SMALL FADERS TO SMALL FADERS and SMALL FADERS TO LARGE FADERS*

As mentioned earlier it is possible to patch additional inputs into the small monitor faders whilst mixing, and routing these, via the A, B, and C buttons in the routing matrix, to those output buses. If these additional inputs are routed to a group instead, they can be picked up by the Large channel fader or the Small monitor fader of that group in exactly the same way as in the first two examples.

This page has been left intentionally blank.

## SIGNAL PROCESSING ROUTING WITHIN THE SL611V I/O MODULE

Each SL611V Input/Output module has seven signal processing buttons, which position the Dynamics, Equaliser and Filter sections in the signal paths.

The first two examples opposite show that the Equaliser and Filters are normally treated as a single unit, which may be switched into either the channel or monitor path.

Note that the Filters follow the equaliser.

The SPLIT Button always splits the filters from the equaliser and places them directly after the Mic/Line switch at the front of the channel. This allows for the equaliser to be placed in the monitor path and the filters in the channel path.

PROCESSOR SWITCHING	INPUT	SIGNAL PROCESSOR PLACEMENT	FADER
---------------------	-------	----------------------------	-------

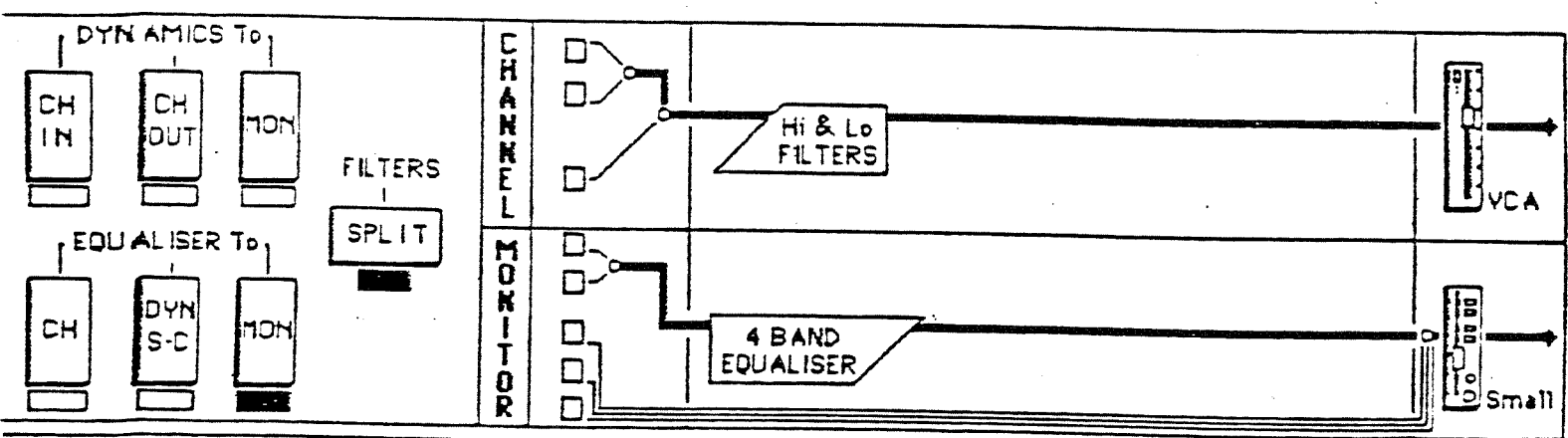
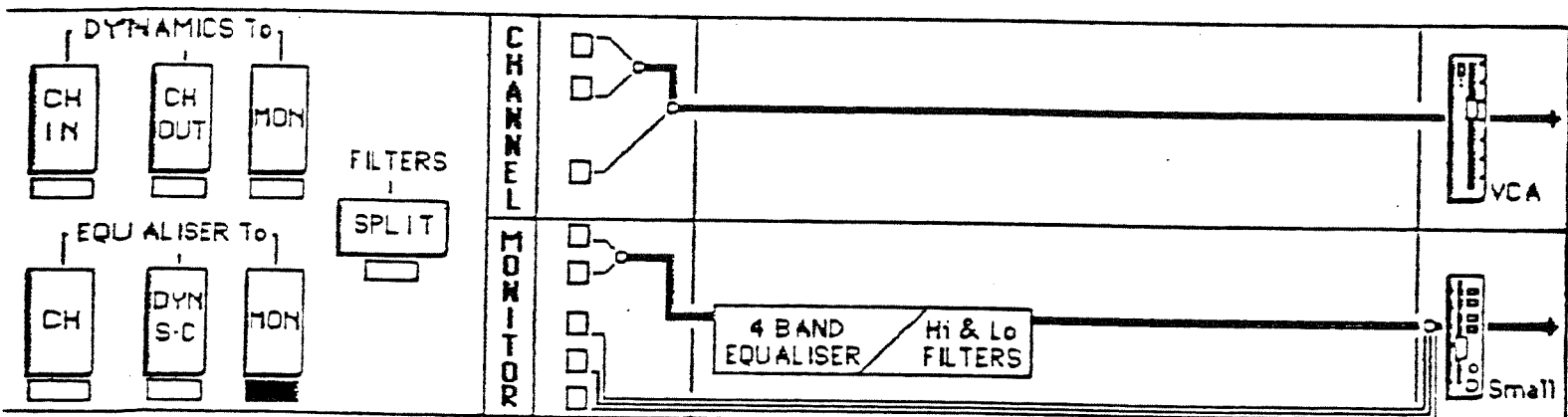
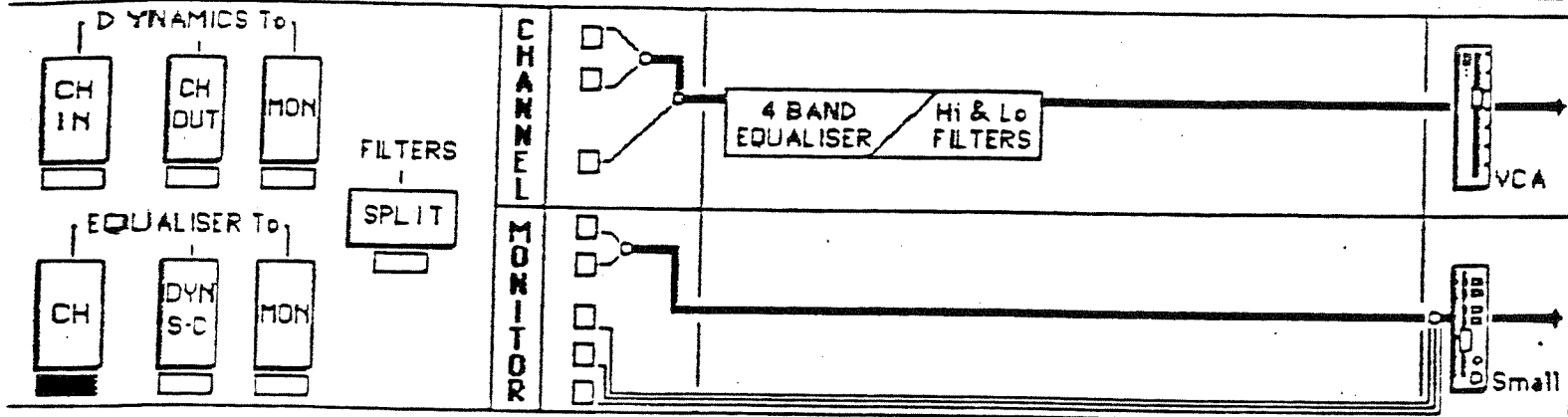

The Dynamics section can also be switched to either the channel or monitor path.

The Equaliser may be placed in the channel and the Dynamics in the monitor.

**PROCESSOR SWITCHING      INPUT      SIGNAL PROCESSOR PLACEMENT      FADER**

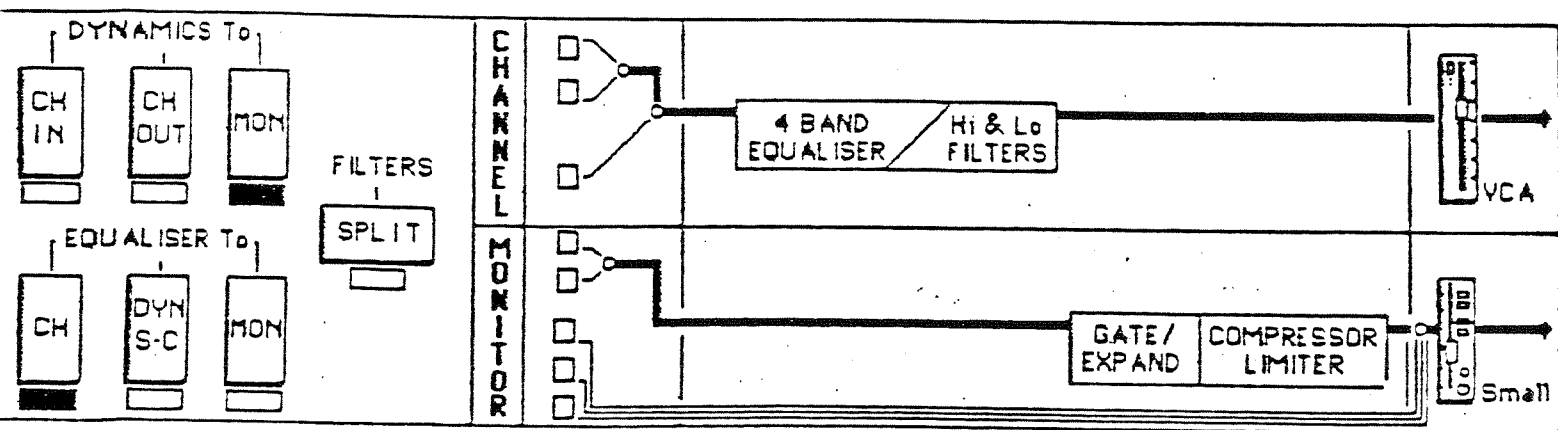
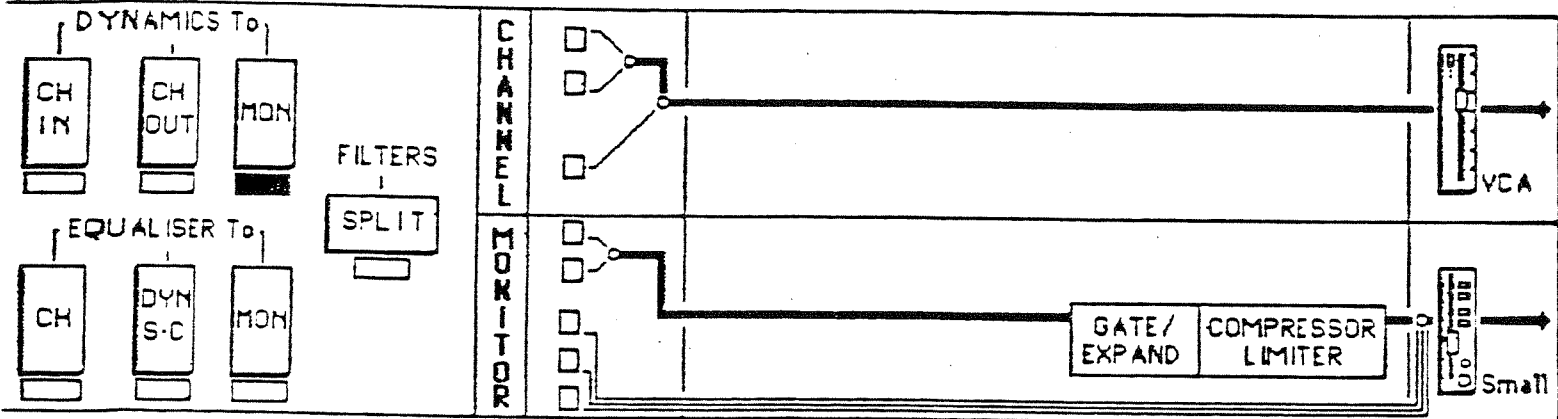
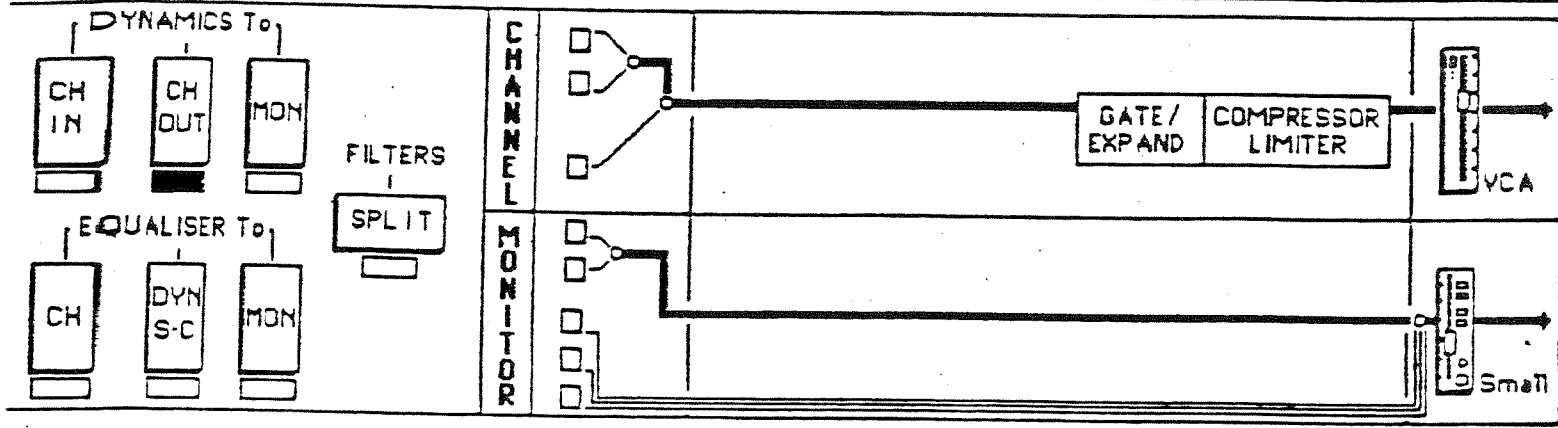

The Equaliser may be placed pre or post Dynamics in the channel.

Using the SPLIT button, the Filters may be placed pre-Dynamics and the Equaliser positioned post-Dynamics in the channel.

Using the SPLIT button, it is also possible to place the Filters in the channel path while the Equaliser and Dynamic sections are in the monitor path although this is not shown. Note that the Dynamics always follows the Equaliser when they are both placed in the monitor path.

**PROCESSOR SWITCHING**

**INPUT**

**SIGNAL PROCESSOR PLACEMENT**

**FADER**

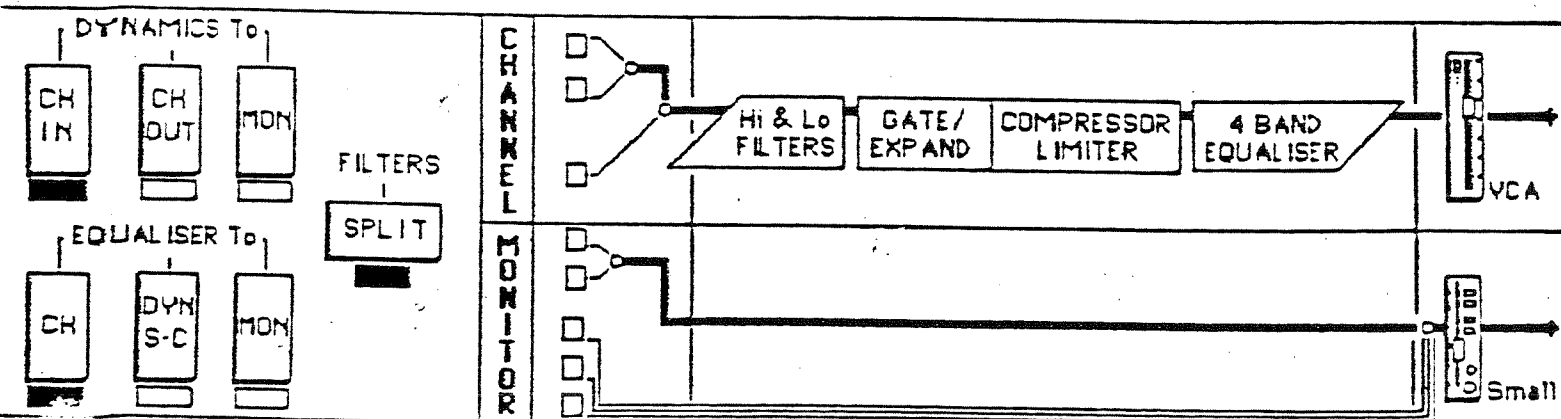
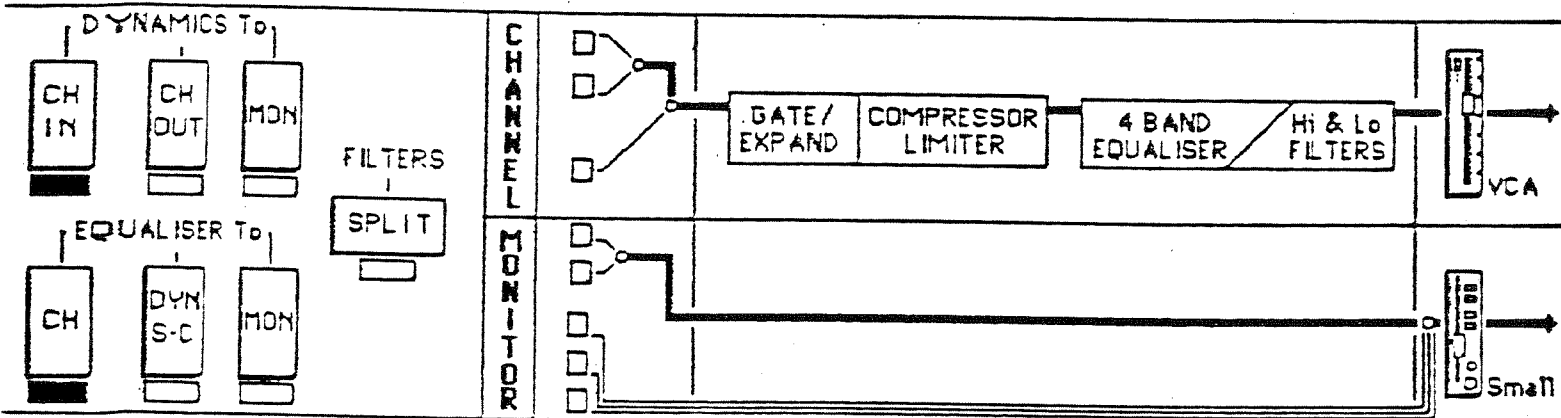
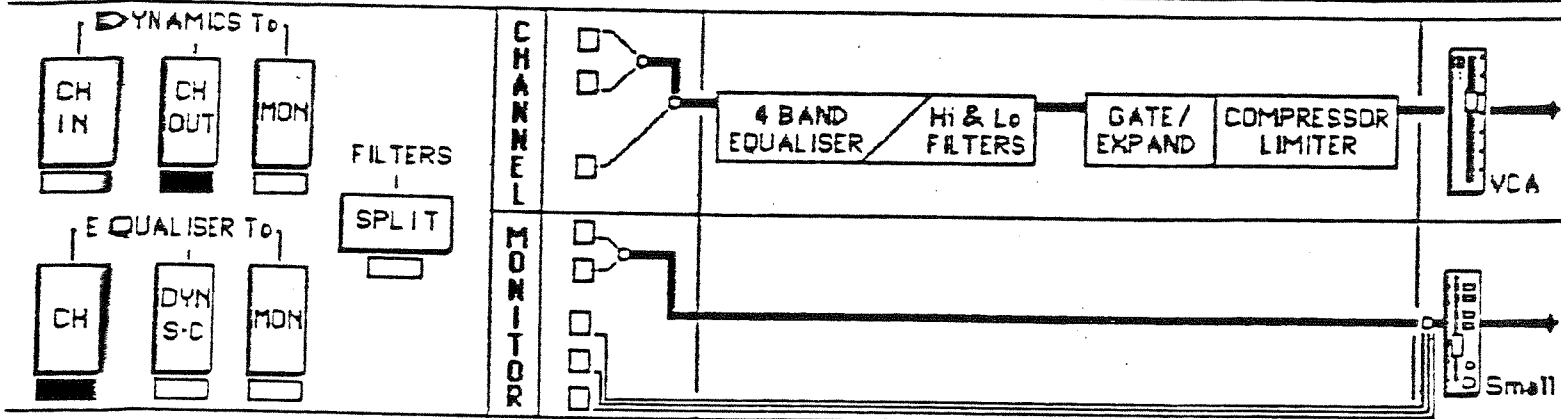

Access is also provided to the level sensing sidechain of the Dynamics section. The Equaliser may be placed in the sidechain of the Dynamics section in either the channel or the monitor path, with or without Filters. Frequency dependent effects such as stressing or de-essing are thus easily achieved.

Selecting Dynamics to Monitor and Dynamics to either CHannel INput or CHannel OutPut allows an external keying signal to control the sidechain. This external keying signal is taken from the Monitor Input pre fader, so patching into the Group Monitor input or Tape Monitor input via the patch accesses this sidechain. As the monitor input can pick up the module's group output (ie module 21 can monitor group output 21) signals can be routed to the module's group via the routing matrix and selected to the side chain input with the READY GROUP button. This application, where a module's dynamics section is keyed from another module, will be covered in more detail in the applications guide.

**PROCESSOR SWITCHING      INPUT      SIGNAL PROCESSOR PLACEMENT      FADER**

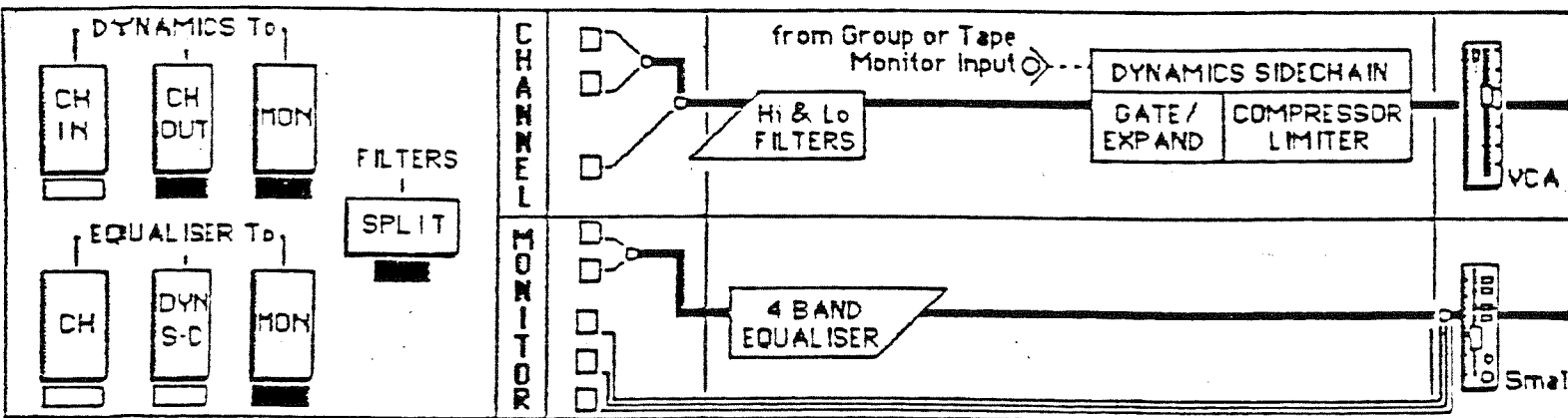
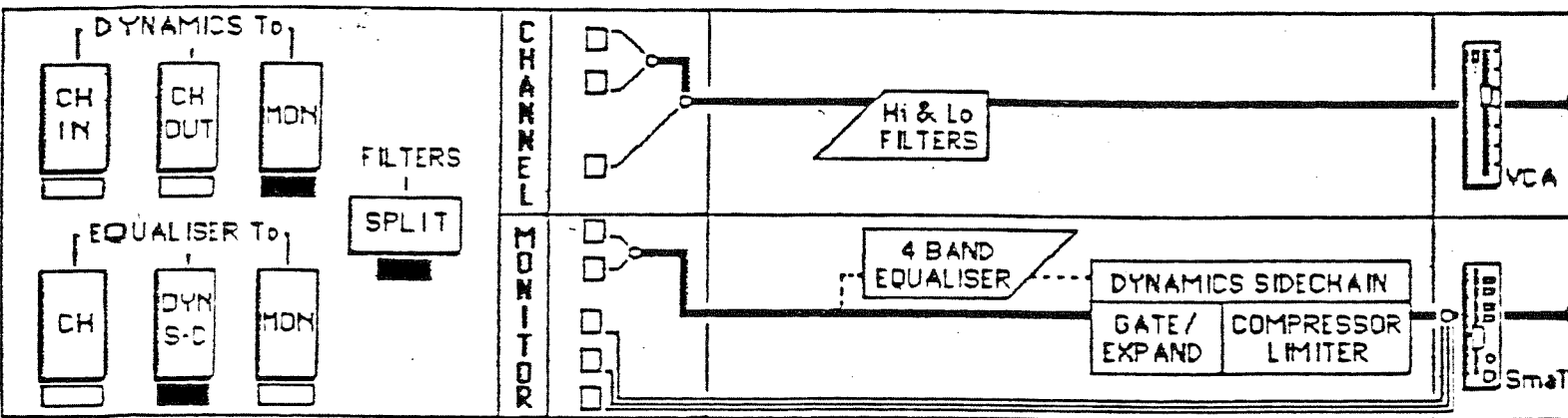
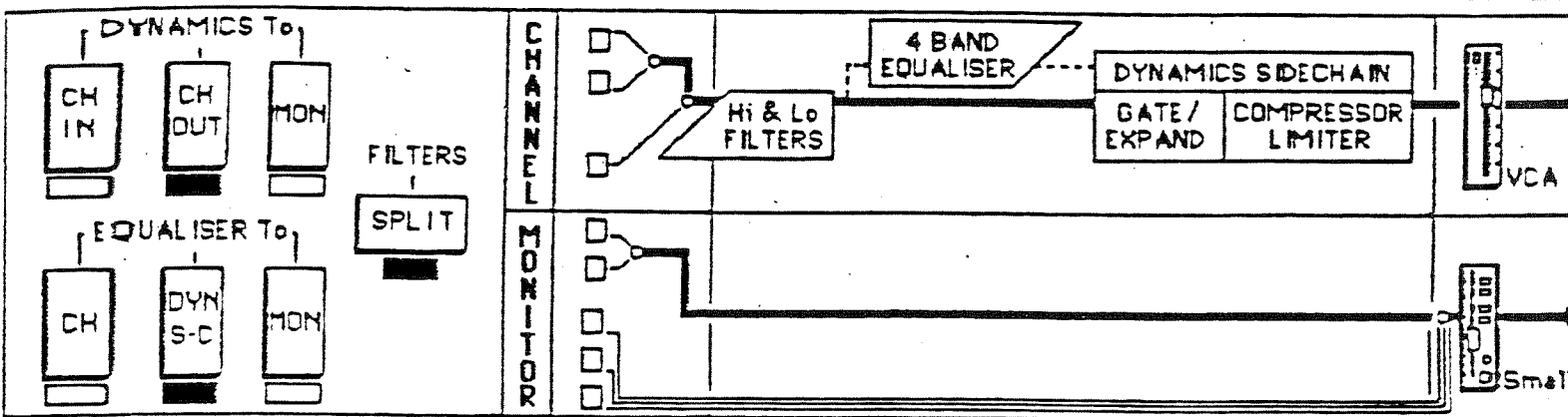

Detailed descriptions of the controls are given in section 6. However it is probably best to start with the basic signal flow through the panel to give you an idea of the routing possibilities and to enable you to see where the main signals go after having been sent from the I/O or the Stereo modules to the A, B and/or C buses.

This panel can be looked at as a mixer within a mixer. It receives three stereo group inputs which have been fed from the modules and mixes these, together with three stereo and three mono tape returns, into the main stereo programme output. Monitoring and control facilities are also incorporated in the panel.

Basically there are four main stereo outputs from the SL 6000 E Series range of consoles; the A, B and C outputs and the main programme output. These outputs may be used in different ways depending on the application. In many cases they will be tied to ATR machines and it is for this reason that the group outputs are labelled 8 track and 4 track ATRs. The three stereo groups could be wired to the first 6 tracks of an 8 track ATR and the mono derived outputs to 3 tracks of a 4 track ATR.

The diagrams that accompany the text show four basic signal flow sections:

1. The A, B, C Group controls and clean feed outputs
2. The feeds to the programme output
3. The feeds to the monitor outputs
4. The A, B, C stereo and mono Tape return controls

Looking at these more closely:

1. The A, B, C Group controls and clean feed outputs

Three stereo group inputs all come from the mixing buses fed from the channel modules. Signals pass through the group trim controls which have a unity gain detent and then through the insert points. If FADERS TO GROUPS is selected the three VCA faders can now control the group levels, after the trim control and inserts, but before the feed to Programme. The three outputs designated A, B, and C on the patch allow feeds of these signals to be sent out of the console to an 8 track ATR, a 24 track ATR, clean feed lines in a broadcast studio or even multichannel speaker matrix inputs for film monitoring. As you will see later these signals may be cross routed or mixed to the main programme output.

2. The feeds to the programme output

The PROGRAMME FROM buttons allow the main stereo programme output to be fed from the groups, the stereo or the mono tape returns. These can be selected one at a time or alternatively the groups may be mixed with the 8 track or the 4 track returns to the programme. By patching external stereo inputs to the stereo tape returns additional stereo inputs such as OB sources may be mixed to programme. The programme output passes through the main SL 651-V module located to the far left of the console centre section. The main fader and the programme compressor are to be found here as they only operate on this main stereo programme feed.

SL688V

SYNCHRONISER STATUS

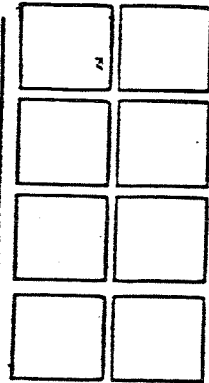
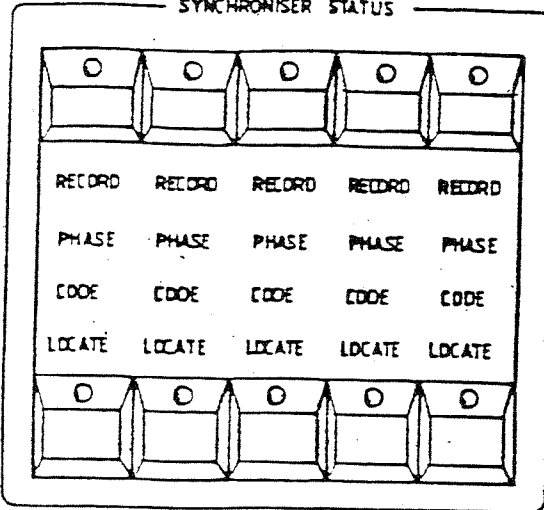

MACHINE STATUS

8 TRACK RECORD ENABLE    4 TRACK RECORD ENABLE

8 TRACK SYNC    4 TRACK SYNC

<p>MONO TRIM OVERLOAD</p> <p>GROUP</p> <p>A TO B    A TO C</p> <p>A TO PROGRAMME</p> <p>MONITOR TAPE</p> <p>RECORD</p> <p>A</p> <p>AFL    MONITOR CUT</p>	<p>MONO TRIM OVERLOAD</p> <p>GROUP</p> <p>B TO A    B TO C</p> <p>B TO PROGRAMME</p> <p>MONITOR TAPE</p> <p>RECORD</p> <p>B</p> <p>AFL    MONITOR CUT</p>	<p>MONO TRIM OVERLOAD</p> <p>GROUP</p> <p>C TO A    C TO B</p> <p>C TO PROGRAMME</p> <p>MONITOR TAPE</p> <p>RECORD</p> <p>C</p> <p>AFL    MONITOR CUT</p>
---------------------------------------------------------------------------------------------------------------------------------------------------------------	---------------------------------------------------------------------------------------------------------------------------------------------------------------	---------------------------------------------------------------------------------------------------------------------------------------------------------------

METER SELECT

8 TRACK GROUP    4 TRACK GROUP

8 TRACK TAPE    4 TRACK TAPE

8 TRIMS  
6 Track to STEREO    3 Track to MONO

FADERS TO GROUPS    FADERS TO MONITORS

PROGRAMME MONITOR FROM

8 TRACK MONITOR    8 TRACK

4 TRACK MONITOR    4 TRACK

A+B+C    PRG

### 3. The feeds to the monitor outputs

The programme output, the 4 track or the 8 track tape returns can be assigned to the monitors by selecting the appropriate MONITOR FROM button. The actual speaker level control and the dim and cut facilities are to found on the SL 651-V Master facilities module.

### 4. The A, B, C stereo and mono Tape return controls

Two tape return sources are included, the three stereo 8 track returns and the three mono 4 track returns. Either one can be selected to feed the monitors or the programme via the MON CUT buttons and the respective level control. By selecting the FADERS TO MONITORS button, the three VCA faders located at the bottom of the centre section may be used to mix these tape return signals. Without the faders the three returns are mixed together with unity gain.

The local controls can be found on the lower left section of the panel and refer to the A, B and C group/tape feeds. The master controls, located to the right of the panel determine monitor, programme, fader, meter and machine modes.

The first diagram opposite shows the panel in standard operational mode. All modules are assigned to Stereo Bus A. The PROGRAMME FROM A+B+C master button and the A TO PROGRAMME local button switch the Stereo Group A output to the programme buses, which are controlled by the master fader on the SL 651-V. This mode of operation is used when monitoring and mixing to stereo with no need for the other facilities of the panel.

12

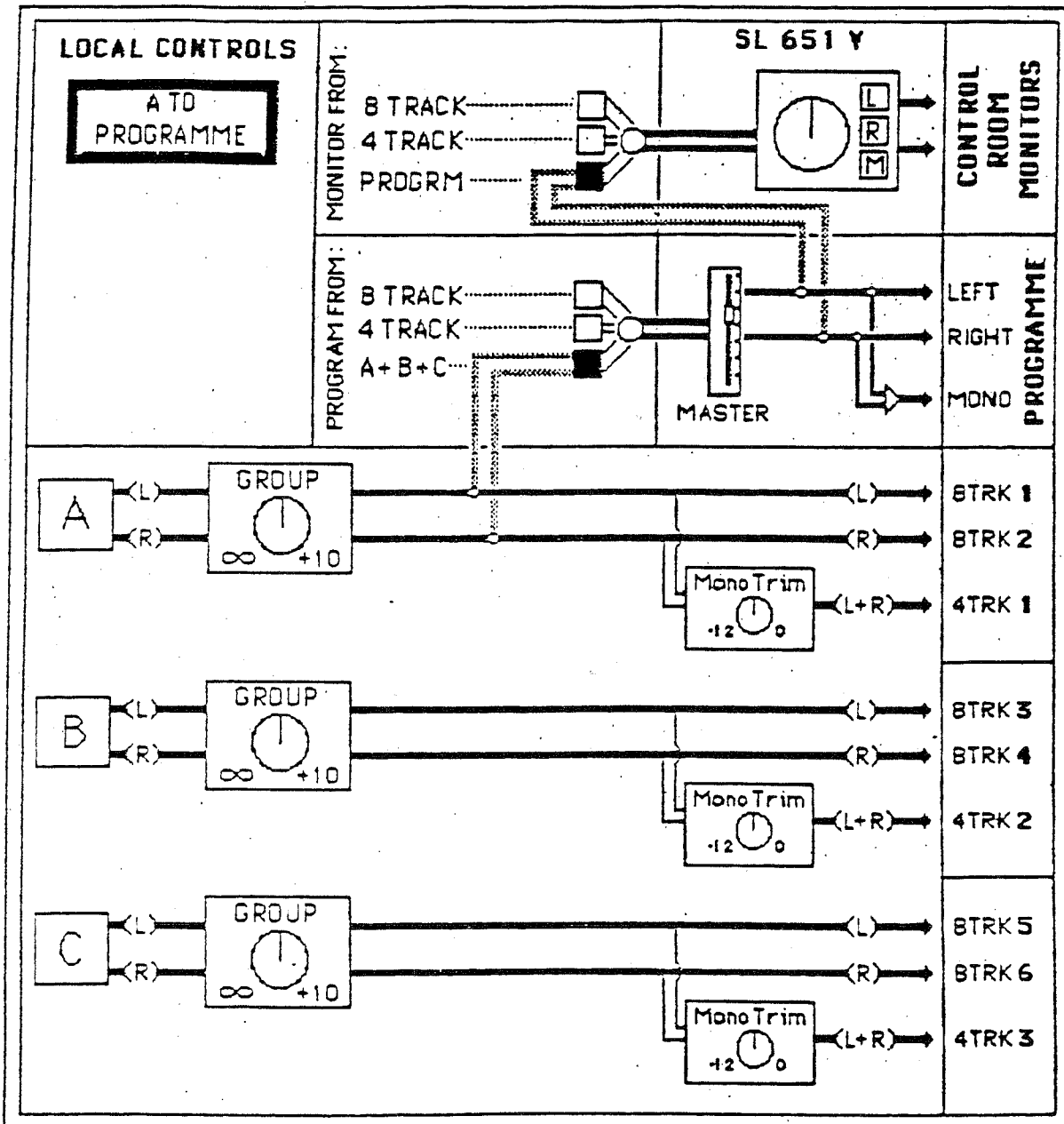

53

16

For multichannel operation, modules may be assigned to any combination of Stereo Buses A, B and C. The Programme and Monitor masters are set as before, and the B TO PROGRAMME and C TO PROGRAMME buttons are also selected.

The Group level controls may be used to adjust the balance between each section; when these are set at their centre detents the A, B and C mixes are summed at unity gain.

This allows the mix to be split into three Stereo Groups whilst simultaneously providing a composite stereo programme output. The three Groups, A, B and C appear on the patch as clean feeds together with their derived mono outputs. The insert points allow compressors or other effects devices to be inserted individually in each Group.

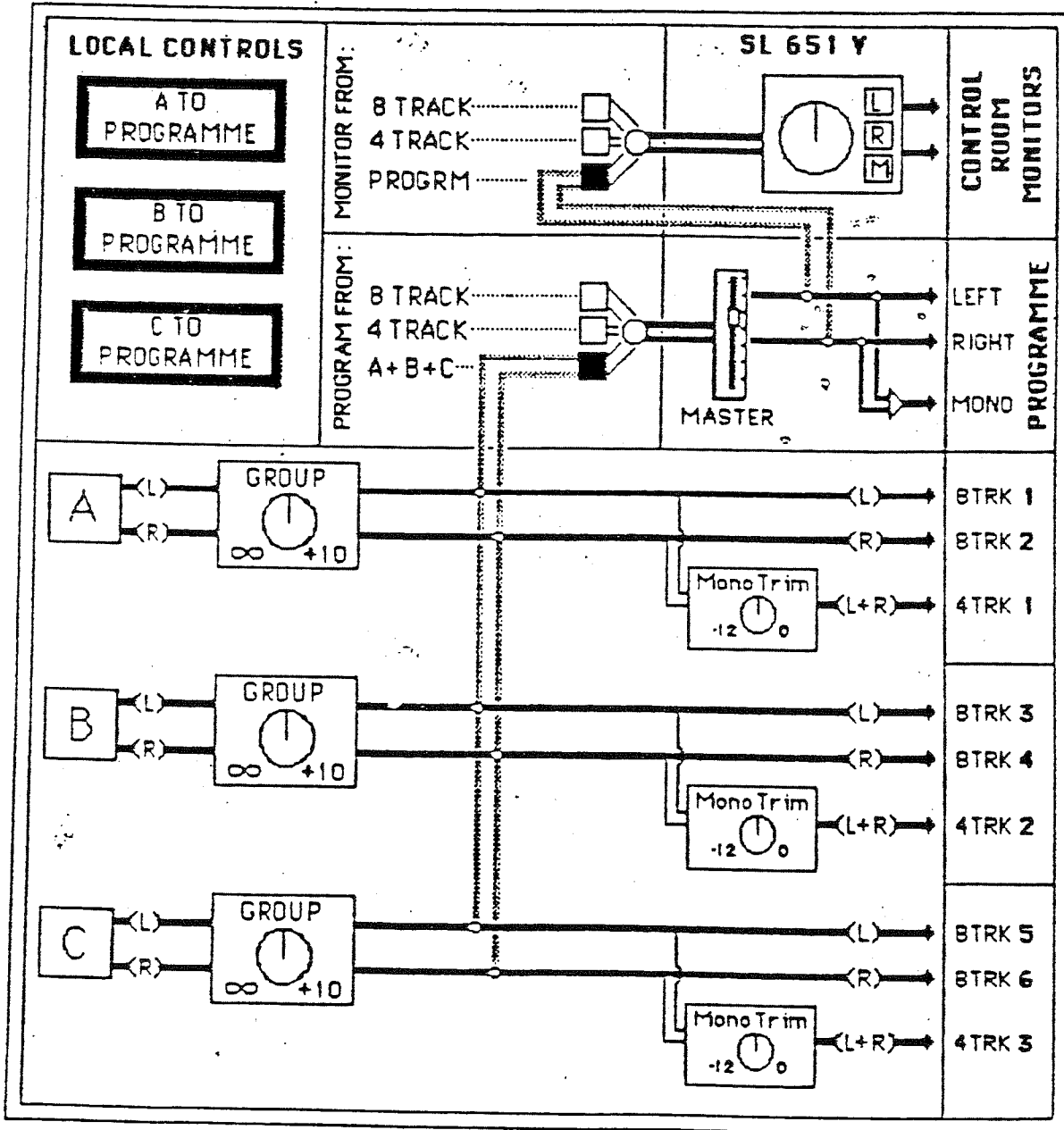

If desired, the stereo faders located beneath each local section in the SL 688-V panel may be switched into the Group signal path. This is useful when the A, B and C Groups are being used to create mix minuses and splits. In the example shown below, four stereo feeds are available at the output distribution row of the patch. The C TO B button cross feeds the C Group to the B bus. Stereo C and A are available as separate mixes, Stereo B as a composite of B and C, and the Programme Mix is a composite of all three. It is clear that there are many different combinations available, making the panel very suitable for deriving multiple, complex, clean feeds.

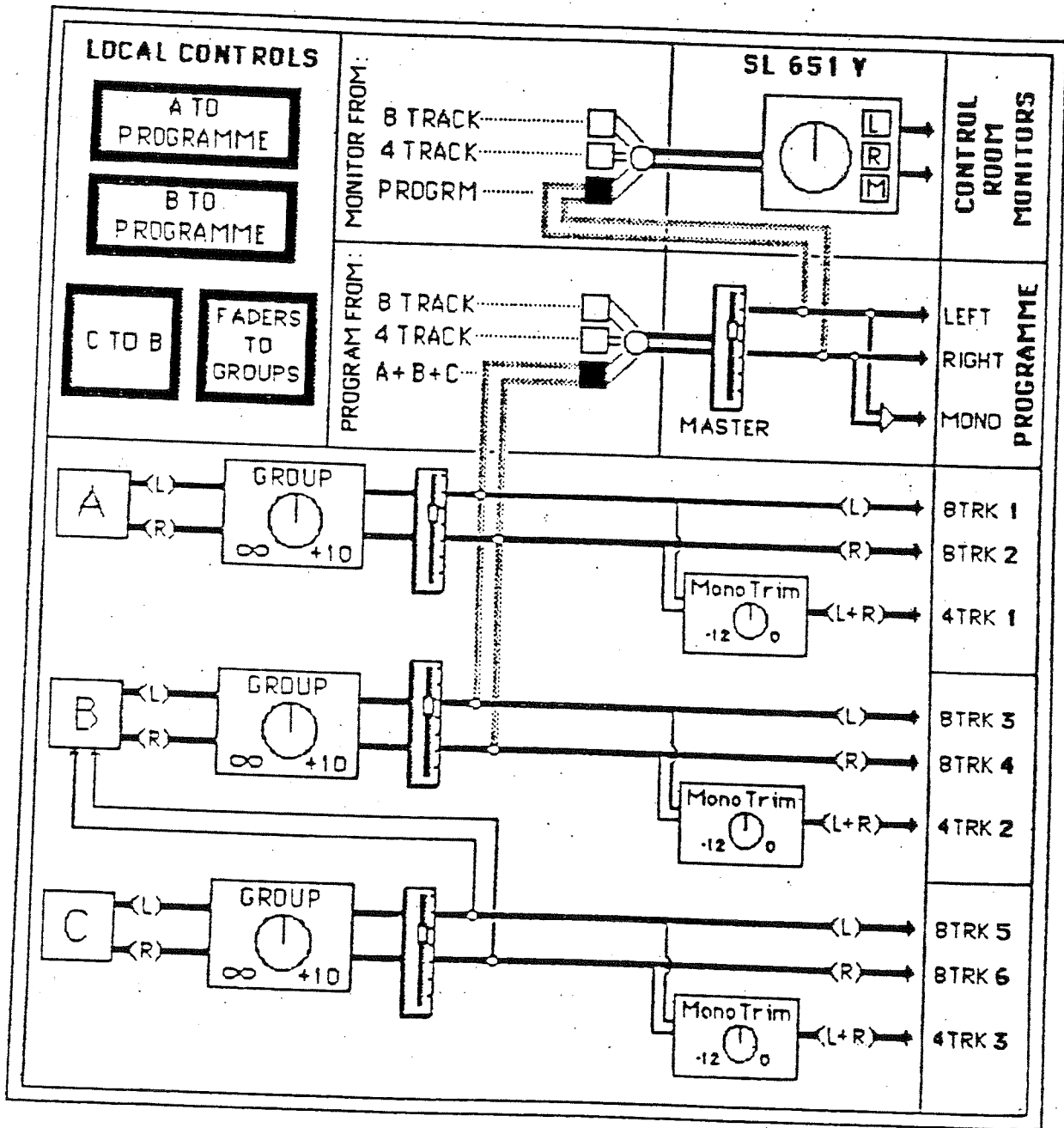

When MONITOR FROM 4 TRACK is selected, the MONITOR TAPE buttons switch between Group sends to the 4 track, and their corresponding Tape returns. In this example the monitors are presented with the Tape returns from tracks 1 and 3, and the Group send to track 2. Facilities in the SL 651-V enable the monitors to be fed stereo, mono left, mono right, or mono Left + Right. Note also that a mono Programme feed is always available.

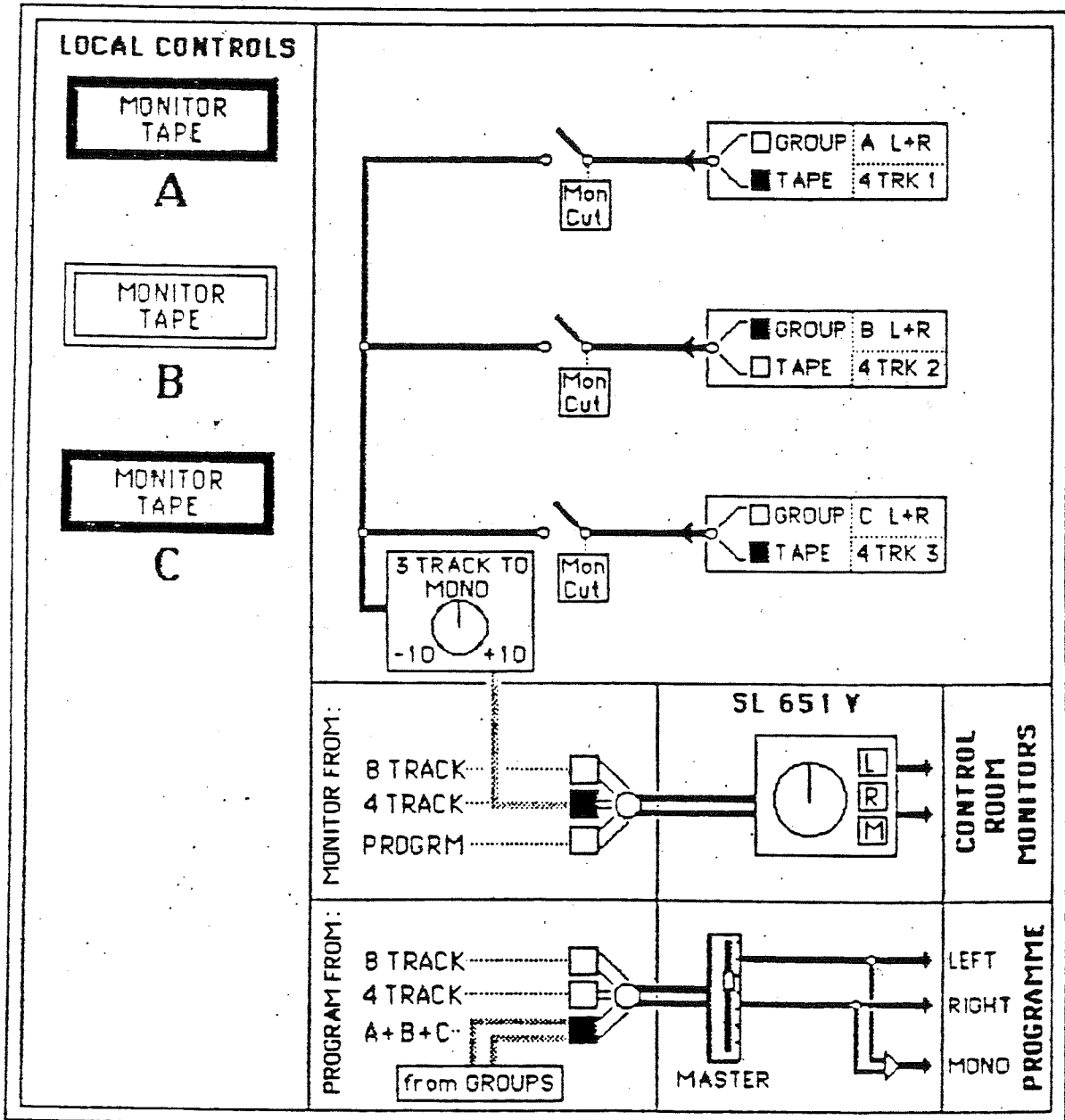

The engineer can monitor either the 8 track or the 4 track ATR without disturbing the Programme feed. When MONITOR FROM 4 TRACK is selected, the local MONITOR TAPE buttons switch between the Group sends to the 8 track and their corresponding pairs of tape returns. In the example shown below, the control room monitors are presented with the Tape returns from tracks 1/2 and 5/6, and the Group sends to tracks 3/4.

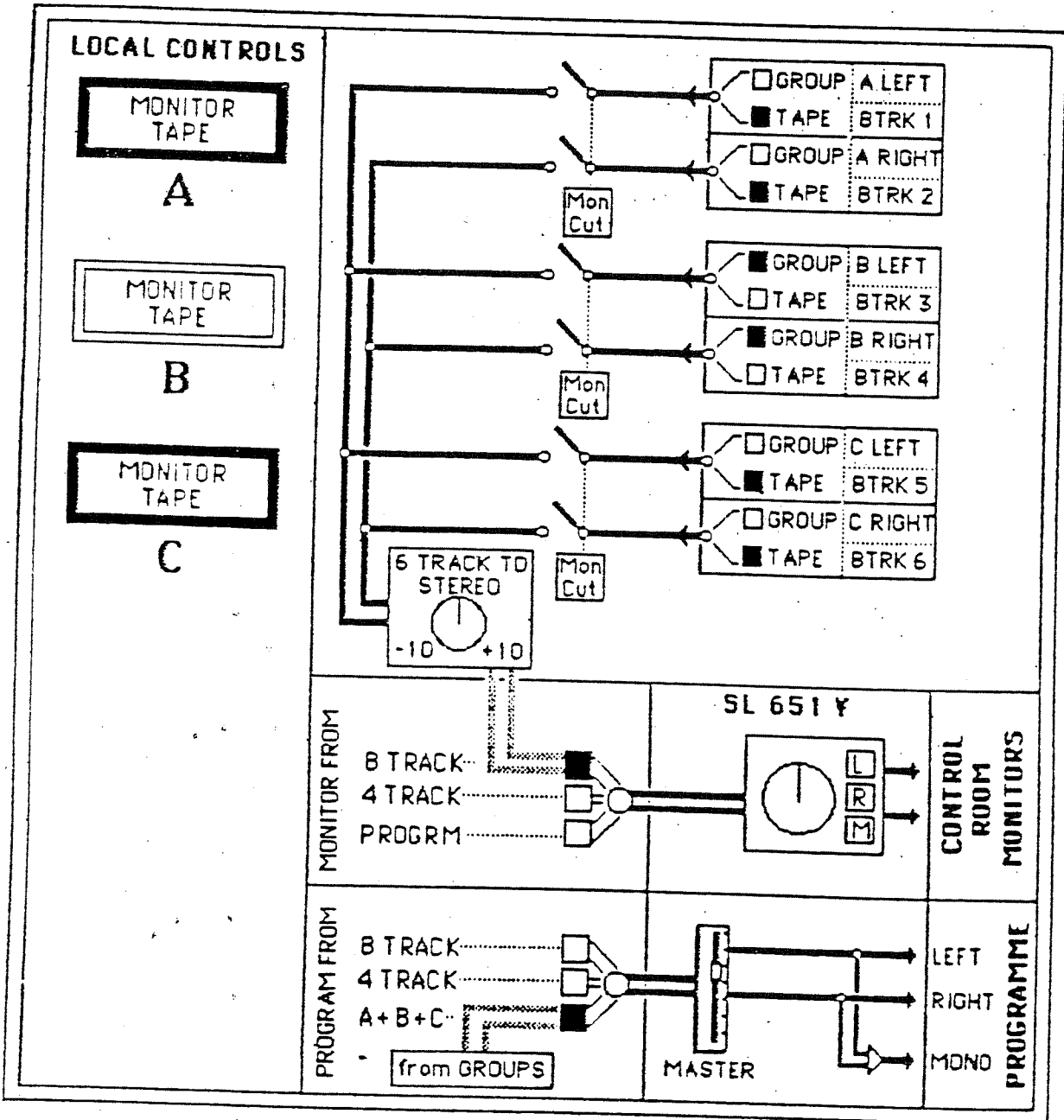

It is possible to derive the Programme from either the 4 or 8 track Tape returns and the A + B + C Groups simultaneously. This allows the SL 688-V panel to serve as a stereo 6 into 2 mixer, without disturbing the main console settings. In the illustration at the right, the Programme has been selected from A + B + C and the 8 Track. It is worth noting that any line level sources can be patched in to the 8 track Tape returns. For example, the MONITOR TAPE A and MONITOR TAPE B buttons could select audio from two 1" VTR's, while MONITOR TAPE C selects a feed from the network.

In this example, the FADERS TO MONITORS button provides each stereo monitor pair with fader control, while the stereo A, B and C buses are mixed using the rotary Group level controls.

These illustrations only begin to suggest the production and post-production capabilities of the SL 6000 E Series Stereo Video system. For the first time, the audio for video mixer can work easily with stereo music effects and dialogue. The broadcaster can produce high quality stereo and mono audio whilst simultaneously producing the submix elements required for Triphonic or SAP formats. These capabilities can also be utilised in recording studios where the engineer is now able to cope with both music recording and audio-for-video post-production.

**LOCAL CONTROLS**

**A TO PROGRAMME**  
**MONITOR TAPE**

**A**

**B TO PROGRAMME**  
**MONITOR TAPE**

**B**

**C TO PROGRAMME**  
**MONITOR TAPE**

**C**

**FADERS TO MONITOR**

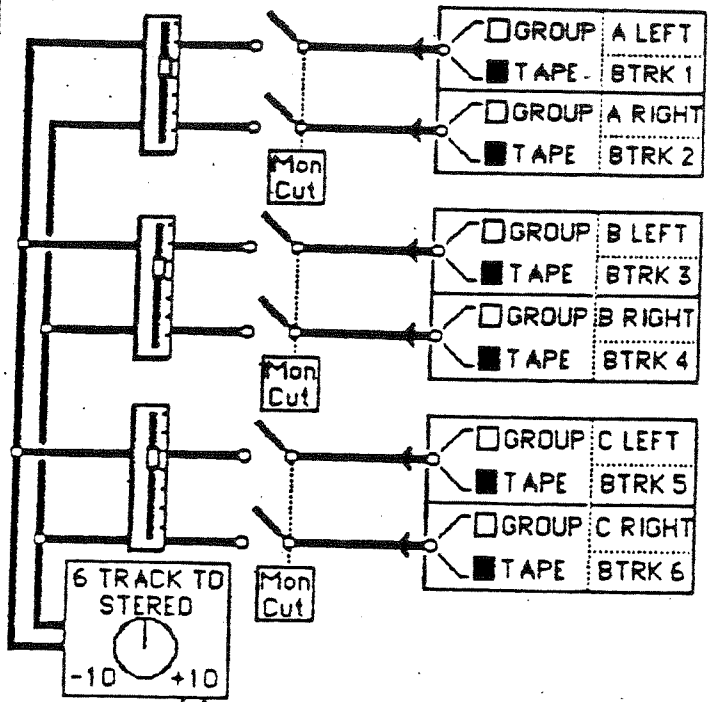

MONITOR FROM:  
PROGRAM FROM:

8 TRACK  
4 TRACK  
PROGRAM

8 TRACK  
4 TRACK  
A+B+C

**SL 651 Y**

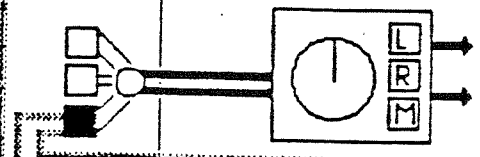

**CONTROL ROOM MONITORS**

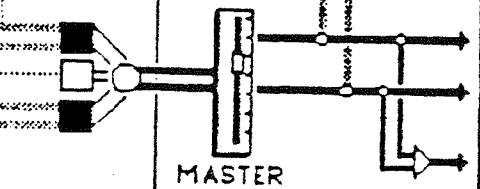

**LEFT  
RIGHT  
MONO  
PROGRAMME**

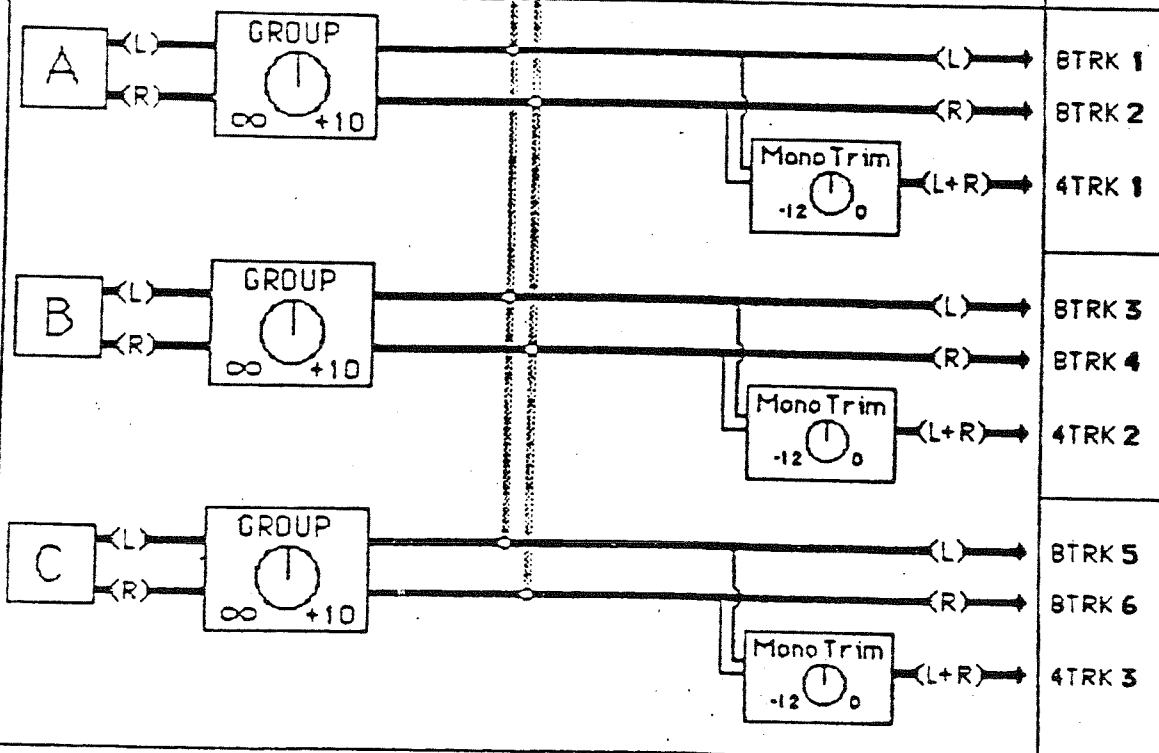



## SECTION 3

# THE SL 611-V INPUT/OUTPUT MODULE

When operating the I/O module it is always important to remember that there are two separate audio paths. Each has its' own input and output section, and each has its' own fader controlling the level. The main signal path (usually controlled by the LARGE VCA FADER) is designated the CHANNEL and the secondary signal path (usually controlled by the SMALL FADER) is designated the MONITOR.

The two input sections are:

The CHANNEL INPUT SECTION and the MONITOR INPUT SECTION.

The two faders are:

The LARGE VCA FADER and the SMALL FADER.

The two outputs are:

The A, B and C BUS SELECTOR (situated at the bottom of the module) and the MULTITRACK GROUP ROUTING MATRIX situated at the top of the module.

Life would be simple (and the console totally inflexible) if there were fixed signal paths through the console. As it is there are many permutations of routing which give the SSL the flexibility that has now become accepted as an essential part of audio mixing. It is these many signal flow permutations that allow the engineer to configure the desk instantly to conform to any task that is presented during a session.

The following section looks at each control individually with brief summaries of the routing. Section 2 of this manual takes a more detailed look at signal flow and routing, including flow diagrams.

## CHANNEL INPUT SECTION

The channel input section may receive any one of three inputs:

**LINE** - Selects a line input from jack row D via the line trim pot (-20db to +20dB). Green LED indicates Line selection.

**MIC** - Selects a microphone input from jack row B via the red mic trim pot (+20dB to +70db). When the module is fitted with a dual line input card this input is a line level input, still from row B but with gain control in the same range as that of the first line input. Red LED indicates this selection. Pulling up the gain control will switch OFF the phantom powering.

**SUB GROUP** - When this button is depressed the other selections are overridden and the input of the channel is taken from that module's group output. The SUB Group button is associated with the patch-free audio sub-grouping facility. On selecting the SUB GP button on modules 1-32, the fader previously being fed from the CHANNEL INPUT SECTION will now pick up its' input from the multitrack bus of the same number. The channel will then become a subgroup. Sources from any of the other modules in the desk may now be sent to that fader via the ROUTING MATRICES. The module GROUP TRIM control can be used as a level control for this input. Both LEDs off show this selection.

**FLIP** - This reverses MIC/LINE selection on each individual channel.

**Ø PHASE** - This reverses the phase of any input selected.

**-20dB** - When pressed this introduces a 20dB pad at the front end of the microphone input.

The MIC and LINE inputs are automatically selected by the STATUS logic switching. In RECORD or REPLAY STATUS all inputs receive MIC INPUT whereas in the MIX STATUS all inputs receive LINE INPUT unless the inputs have been FLIPPed individually or on a master basis. The MASTER CH INPUT FLIP button situated on the 651 panel reverses the input status of all channels.

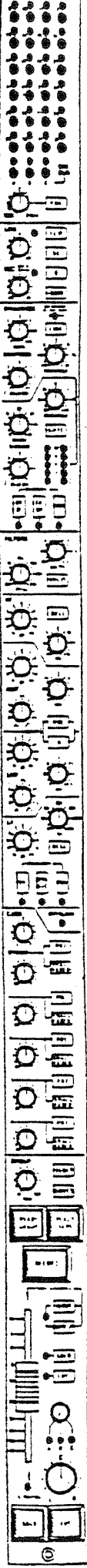
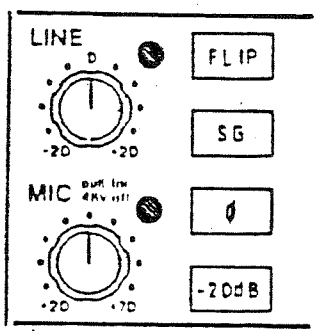

## DYNAMICS SECTION

The dynamics section comprises a compressor/limiter as well as an expander/gate. Both sections work independently but can both be operational at the same time thus providing sophisticated dynamics control of either the channel or monitor signal.

The dynamics section has three routing buttons associated with it. Section 2 details the routing of this section in more detail, but briefly these buttons function as below:

CH IN - Switches the dynamics into the channel audio path PRE EQ

CH OUT - Switches the dynamics into the channel audio path POST EQ

MON - Switches the dynamics into the monitor audio path (POST EQ if the EQ has also been selected to the monitor audio path).

If both the CH IN (or CH OUT) and the MON button are selected then the dynamics section is switched PRE (or POST) EQ into the channel and the side chain can be accessed from the monitor (after the READY GROUP and READY TAPE selection buttons). This allows the section's side chain (key input) to be fed from an external source via the patch (plug into the TAPE MONITOR jack) or via the module's group (route the key signal via the multitrack matrix to that module's group then select READY GROUP on the module).

These buttons are related to the CH, DYN-SC, MON and SPLIT on the Equaliser section allowing many different EQ, FILTER and DYNAMICS routing combinations, including routing the dynamics side chain through the EQ section for special effects. Again, complete routing details can be found in section 2.

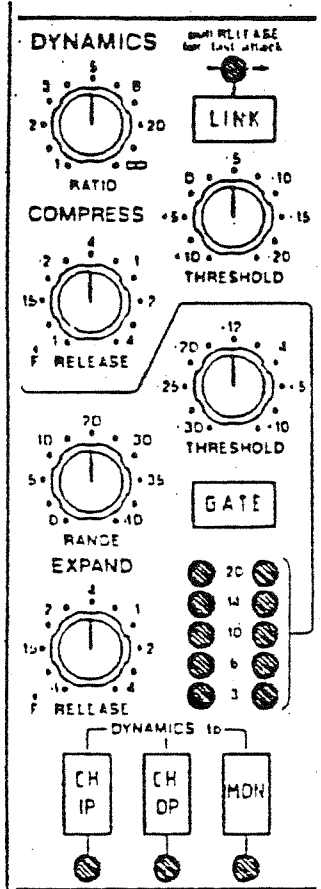

## COMPRESSOR/LIMITER

Controls are:

**RATIO** - When turned to 1:1 the section is inactive. Turning the control clockwise increases the compression ratio to give a true peak limiter in the fully clockwise position.

**THRESHOLD** - Does exactly what it says with the additional feature of automatic gain make-up (ie. as you lower the threshold, and hence introduce more compression, the output level is increased. This effectively maintains a steady output level regardless of the amount of compression. This feature allows you to alter the amount of compression without having to vary the level of the compressed signal at the same time)

**RELEASE TIME** - Variable from .1 - 4 seconds this control also incorporates a switch which, when pulled up, provides fast attack (3ms for 20dB Gain Reduction). When down it switches to Program Controlled Attack (3ms-30ms).

The yellow and red LEDs indicate the gain reduction.

## EXPANDER/GATE

This section can act as a 2:1 Expander when the GATE button is UP or as a 20:1 Gate when the GATE button is depressed. Controls are:

**RANGE** - Determines the depth of Gating or Expansion. When turned fully anticlockwise (range = 0) this section is inactive and when turned fully clockwise the max range of 50dB can be obtained.

**THRESHOLD** - Level hysteresis is incorporated within the Threshold circuitry. For any given 'open' setting, the Exp/Gate will have a 9dB lower 'close' threshold. This is very useful as it allows instruments to decay below the 'open' threshold before they are Gated out or Expanded down.

**RELEASE TIME** - Variable from .1 - 4 seconds this control also incorporates a switch which, when pulled up, provides fast attack (100us per 40db). When down it switches to a controlled linear attack time of 1.5ms per 40dB.

The green LEDs indicate the Expander/Gate activity.

The LINK button at the top of the section links the side-chain signal of that unit to the side-chain of the next Dynamics section along to the right. Note that the Dynamics section is completely bypassed if none of the three routing buttons are depressed and so the side chain will not receive any input unless the section is switched into circuit.

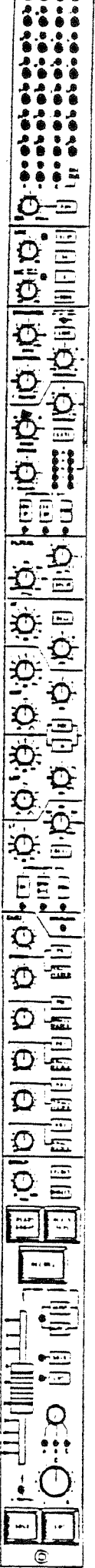
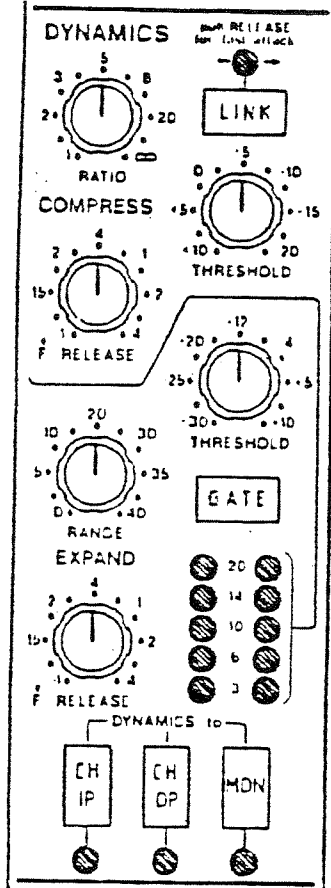

## FILTERS AND PARAMETRIC EQUALISER SECTION

The section comprises a four band Parametric Equaliser plus a High and Low pass filter section. These two sections are separate and can be routed to different audio paths within the module. There are four routing buttons associated with this section of the module. Section 2 shows the routing combinations in more detail but briefly these buttons function as described below:

**CH** - Switches the section into the the channel audio path. The Filters follow the Parametric EQ.

**DYN SC** - The section is switched into the side chain of the dynamics section. The Filters follow the Parametric EQ.

**MON** - The section is switched into the monitor audio path. The filters follow the Parametric EQ. The section is before the dynamics section if this has also been selected to the monitor audio path.

**SPLIT** - Can be operated in combination with the above selections and always splits off the FILTERS and puts them at the very front of the channel audio path, before any other signal processing device.

This allows the filters to be used in the channels feeding to the multitrack whilst in RECORD, the parametric EQ being used on the monitors only. This is also useful when additional inputs are being brought into the mix, whilst in MIX mode, on the SMALL FADERS. The filters can be used on the signal passing through the channel via the LARGE FADER and the parametric EQ used on the signal being brought through the monitor section via the SMALL FADERS. If the parametric EQ is used in the Dynamics side-chain the SPLIT button can be used to free the filters for use in the channel audio path.

As with the Dynamics section the EQ is completely bypassed when none of the routing buttons are depressed.

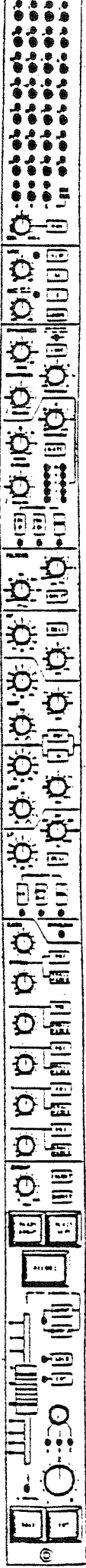
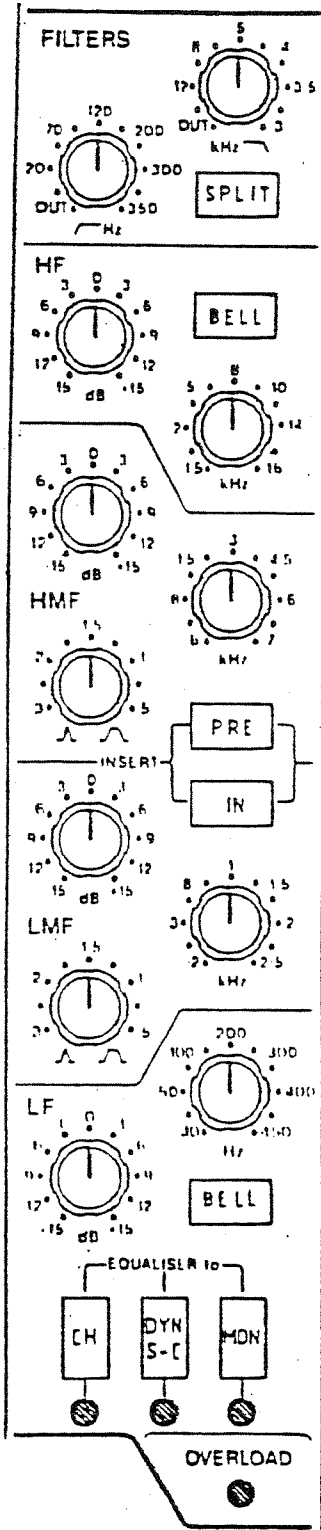

## PARAMETRIC EQ

BELL - The HF and LF sections have switchable BELL (Peak) and Shelf characteristics. Each of the gain controls has a centre detent at 0db Gain so that they may be returned to the zero position accurately when that particular section is not in use.

The HMF and LMF bands of the parametric EQ have continuously variable bandwidth (Q). This measurement of the shape of the EQ curve is calculated as the ratio of Gain/Bandwidth. Note that the Frequency bands overlap considerably allowing flexibility of control.

## FILTERS

The filters can be switched out when the controls are turned fully anticlockwise. Newer consoles have switches built into the controls so that when fully anticlockwise the filters are completely bypassed. On older consoles all the routing buttons must be switched out to accomplish this. The High pass filter has a slope of 18dB per Octave and the Low pass filter has a slope of 12dB per octave.

## OVERLOAD INDICATOR

This overload circuit monitors the signal through the channel at three different points and gives an indication when the signal is within 4dB of clipping. The monitor points are: post- channel fader, post-insert point, channel front end pre any signal processing.

## INSERT POINT

The insert point is switchable PRE or post the EQ before the fader. The insert send jack (Row E) always carries the channel signal and is normalled down to the insert return jack (Row F). The IN button switches the return back into the channel signal path, hence switching in any device patched to the insert jacks.

There are two different insert point options set by links on the I/O module mothercard. When the Insert point links have been set to CHANNEL, the insert point will always be in the channel no matter where the EQ is. When the links are set for the insert point following the EQ the insert point can only be switched in when the EQ is switched into an audio path. In this case the insert point follows the EQ, so if the EQ is in the MON audio path then the insert point will also be in the MONITOR path.

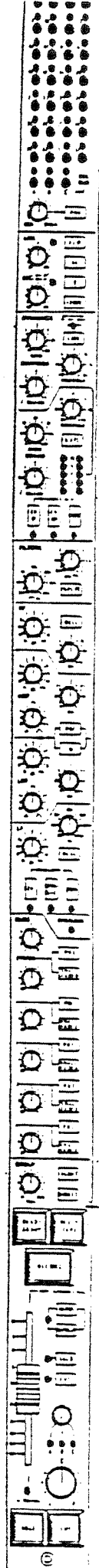
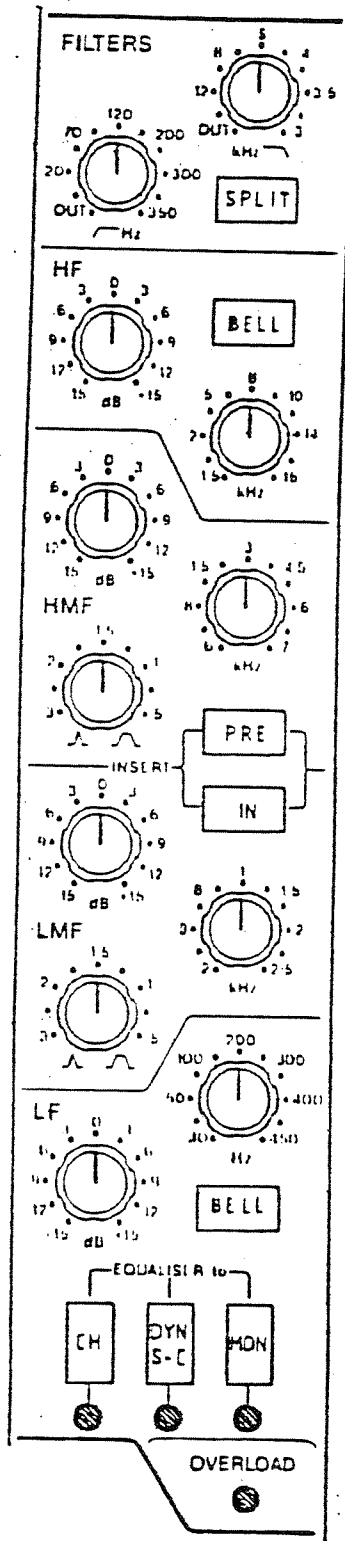

## CUE AND AUX SENDS

The section comprises one stereo and four mono sends. Either audio path, controlled by the LARGE or SMALL fader, from each module may be routed to any of the send buses, in any Pre or Post-fader permutation.

Each send has a level control with a built in push-on/push-off switch so that levels may be preset and easily switched on or off. When the pot is up it is off. The stereo send also has a pan control.

The source select buttons for each send are:

PRE - When pushed down the send is derived pre-fader, and when up, post-fader.

SMALL FADER - When pushed down the send is derived from the SMALL FADER signal path and when up, the send is from the LARGE FADER signal path.

During the recording process the stereo and the first two mono buses may be used as headphone feeds. All the aux send buses are found on the jackfield (jacks N1-6) and can be used as feeds to effects units. The stereo and the first two mono sends are simultaneously routed back into the centre section (jacks P5-8) where talkback and additional external stereo feeds, via the CUES pot, can be added.

After the addition of talkback, stereo reverb from the stereo reverb returns, and a stereo external source the cues appear on the patch row N9-14. These outputs are then normalised to the feeds to the headphone power amps (jacks P9-14).

CUE 1L & 1R are derived from AUX 1, and CUE 2L & 2R are derived from AUX 2. CUE 1 and CUE 2 will be mono unless a stereo external source or stereo reverb has been added whereas CUE STEREO is a true stereo send derived from the stereo Aux bus.

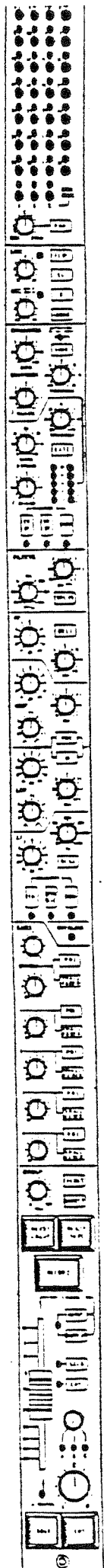
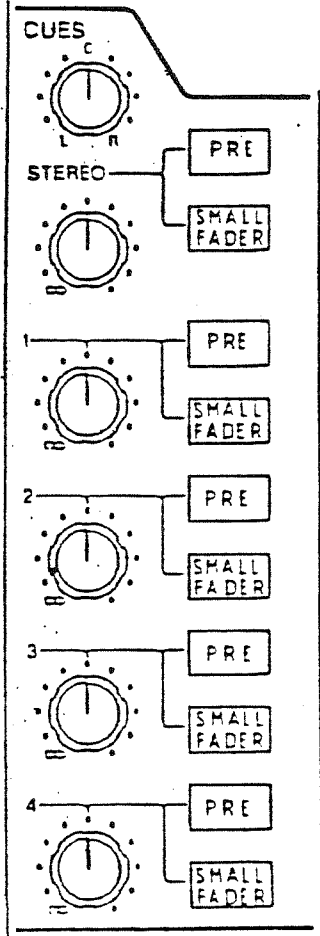

## GROUP OUTPUT SECTION

This section comprises of a group mixing amp with gain control and the FLOAT and DIRECT routing buttons.

The Group section takes its' input from the associated multitrack mix bus. (eg. All signals routed to multitrack group 7 will be controlled by the group section on module 7). The output of the group amplifier appears on patch row G where the signal is normalled down to the multitrack send (ie. to the record inputs of the multitrack) and into the group monitor button, located at the top of the small fader section.

The GROUP TRIM control varies the level of the group output. Normally these controls are left fully up and have detents in this position. Their main use is for attenuating a group output when, for example, several channels have been assigned to a group and the relative balance has been set on the faders. If the overall signal level is too high then the group trim control is the means by which the combined group output can be adjusted to send an optimum level to the multitrack.

When the GROUP outputs are not being used as multitrack sends they may be routed to the corresponding CHANNEL INPUT SECTION, by pressing SUB GP on that module. The channel will now act as an audio subgroup and the group trim control as the channel input gain control.

FLOAT - The FLOAT button reroutes whichever of the two faders is currently assigned to the MAIN A, B or C output groups up to the ROUTING MATRIX, in order to facilitate track bouncing and audio subgrouping arrangements. Note that the other fader's routing destination is then disabled. This is not a fader flip button.

DIRECT - The DIRECT button provides a means of routing the post-channel fader signal on that module DIRECT to the corresponding multitrack GROUP output, bypassing the routing MATRIX, GROUP mixing bus, GROUP mix amp and GROUP TRIM control. This improves noise figures but disables all other channels routed to that GROUP output as the GROUP mix bus is not used. This button also allows channels above 32 to access their own GROUP output (eg. GROUP 33 can only be accessed from channel 33 with the DIRECT button depressed). The GROUP outputs from 33 onwards can therefore be used as additional sends to a second multitrack during live recording or as direct channel outputs. Remember also that the insert send jack always (unless the console has the 'follow EQ' insert option - see P.3-10) carries the channel signal so this may also be used as a direct output in the last resort.

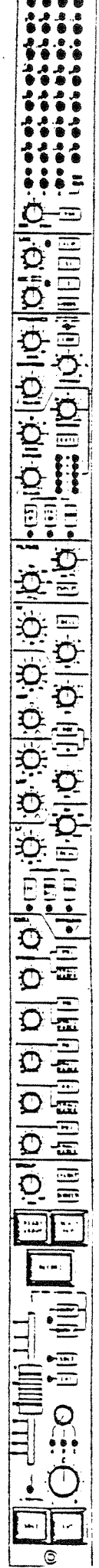
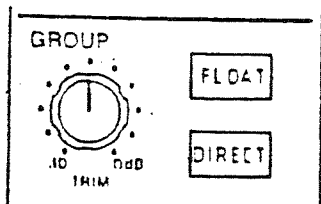

## ROUTING MATRIX

The console has as many group outputs as there are I/O modules. The routing matrix allows any of the modules to route to the first 32 of these output groups, together with the main A, B OR C STEREO MIX bus outputs.

The matrix may be fed from either fader path depending on the main STATUS controls and the individual module FLOAT buttons.

There are four main uses for this matrix:

1. In RECORD or REPLAY status the channel signal can be fed to any multitrack group for laying to multitrack, usually from the LARGE FADER but also, if the VCA TO MON or module FLOAT button is depressed, from the SMALL FADER.

2. In MIX status either the SMALL or the LARGE FADER (when the FLOAT button is depressed) can send up to the routing for audio subgrouping to any of the first 32 channels. Having been routed up to the groups this signal can be picked up on the corresponding LARGE FADER by depressing the SUB GP button, or on the SMALL FADER by depressing READY GROUP button.

3. In MIX mode the SMALL FADER can be used as an additional send to a group. Using the INPUT and OUTPUT buttons next to the SMALL FADER, the channel PRE or POST signal processing, or POST channel fader signal can be routed out to a multitrack group and then patched to an effects unit input as an effects send.

*Buttons Selected*

*Source of Monitor Fader Input*

---

INPUT	Pre-Signal Processing but after Filters if SPLIT
INPUT & OUTPUT	Post-Signal Processing but Pre-LARGE FADER
OUTPUT	Post-LARGE FADER

Note that these buttons are also active in the RECORD mode.

4. In MIX mode as a way of accessing the main A, B and C output groups from the SMALL FADERS. Additional line inputs (or, with additional SSL Dual Mic preamps fitted, mic inputs) can be sent from the SMALL FADER to the A, B and C output buses so allowing twice as many inputs to the buses as there are modules.

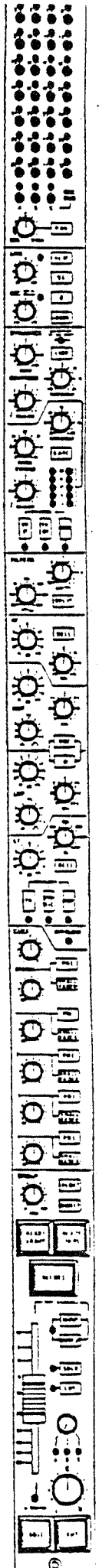
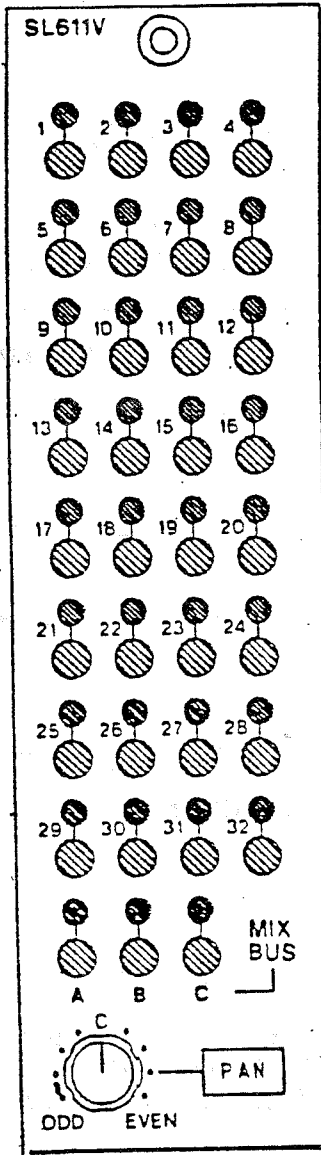

The matrix allows a signal to be routed to any number of the destinations at once. Stereo panning between groups can be achieved by selecting two groups, switching in the PAN control and panning between the Even and Odd groups selected (the odd group is the left of the pair and the even group is the right). Note that the A, B and C buses are stereo buses and if they are selected, and if the Pan control is not switched in, the signal will be sent to the left and right feeds of these buses in equal amounts.

### ROUTING MATRIX & THE STATUS LOGIC SWITCHING

<i>STATUS</i>	<i>ROUTING MATRIX FED FROM</i>
RECORD/REPLAY	Ch Input via LARGE FADER
RECORD/REPLY + VCA TO MON	Ch Input via SMALL FADER
RECORD/REPLAY + module FLOAT	Mon Input via SMALL FADER
RECORD/REPLAY + VCA TO MON + module FLOAT	Mon Input via LARGE FADER
MIX	Mon Input via SMALL FADER
MIX + module FLOAT	Ch Input via Large Fader

NOTE that the easiest way to tell where the matrix is fed from, is to look at the LED situated below the SMALL FADER. When lit, the SMALL FADER feeds the routing and when off, the LARGE FADER is feeding the routing.

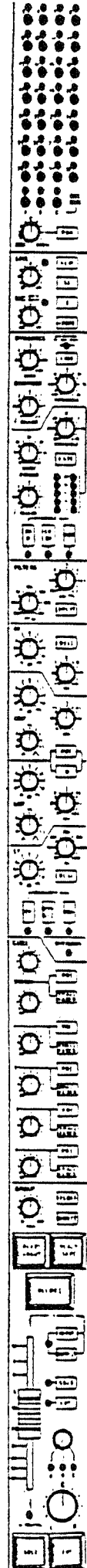
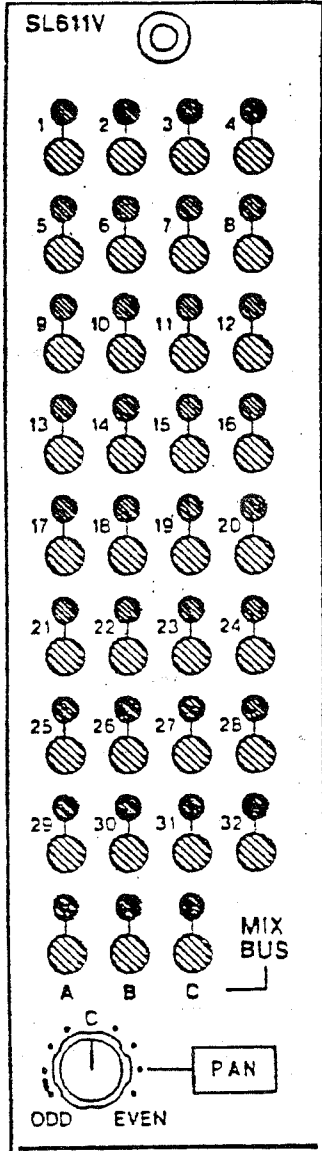

*MONITOR INPUT SECTION*

The source selected by the MONITOR INPUT SECTION is governed by the state of the READY TAPE and READY GROUP buttons and the INPUT and OUTPUT buttons. Note that the INPUT and OUTPUT buttons override the READY TAPE and READY GROUP buttons, but we will assume that they have not been pressed at the moment.

The READY TAPE and READY GROUP buttons serve two functions:

1. These buttons select which input will be presented to the monitor fader; the GROUP signal feeding the multitrack and/or the TAPE return from the multitrack machine.
2. The second function of these buttons is to allow the RECORD button to function as a TRACK READY button.

Each RECORD button is connected to the corresponding multitrack TRACK READY remote. The RECORD button is only READY (allowed) to prime a track for record if either one of the READY TAPE or READY GROUP buttons is depressed. This acts as a safety feature to prevent accidental record priming.

The RECORD button is engraved with the module and track number to clearly indicate which tracks are being primed for record. If the track RECORD button is on, then that track on the multitrack will drop into record if the transport RECORD button is on. Some machines allow the module RECORD button to drop the machine directly into record whilst the machine is running in record. Other machines need a transport RECORD command before a primed track will go into record. You should check the logic of this before dropping in for real!

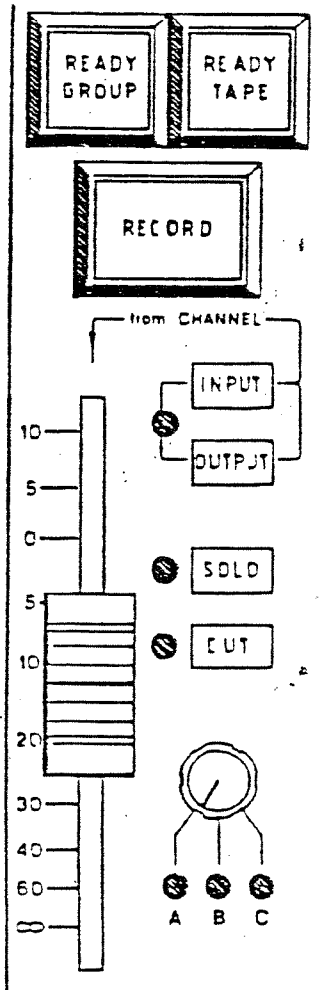

## READY GROUP/TAPE SELECTIONS AND THE SUPERCUE FACILITIES

The READY TAPE and READY GROUP buttons are used to select monitor sources for the monitor fader and for the pre-fader cue feeds. As already described, these buttons also enable the track RECORD button. The table below lists the different combinations of buttons and the resultant signals that are fed to the monitor fader and the cue feeds:

<i>READY BUTTON SELECTED</i>	<i>MONITOR FADER SOURCE</i>	<i>PRE-FADER CUE FEEDS</i>	<i>TRACK RECORD BUTTON ENABLED</i>
NONE	TAPE	TAPE	NO
TAPE	TAPE	GROUP+TAPE	YES
GROUP	GROUP	GROUP	YES
GROUP+TAPE	GROUP+TAPE	GROUP+TAPE	YES

As can be seen above, both Group Output and Tape (ie ATR replay) can be monitored together when both READY TAPE and READY GROUP buttons are depressed. This is presented as a 1:1 mix. Note also that when the READY TAPE button is pressed on its' own, the cue feeds still receive a combination of Group and Tape allowing the engineer to hear the drop-in whilst the artist can hear both himself (or herself) as well as the feed from the sync head of the ATR.

This table applies whilst the machine is not running in record. The SSL Console senses the machine record line and then adjusts the monitor sources accordingly. This system of automatic source selection is called the SSL SUPERCUE System.

Let's first look at the Monitor Fader source before and during the drop-in. The following table shows the sources that will be selected:

<i>READY BUTTON SELECTED</i>	<i>MONITOR FADER SOURCE PRE-DROP-IN</i>	<i>MONITOR FADER SOURCE DURING DROP-IN</i>
NONE	TAPE	TAPE**
TAPE	TAPE	TAPE**
GROUP	GROUP	GROUP
GROUP+TAPE	GROUP+TAPE	GROUP*

\*\* Note that if the machine switches to input during the drop-in, as is usually the case, then you will actually hear the Group output during the drop-in by monitoring TAPE. This sounds confusing but it does actually make sense!

and for the pre-fader cue feeds:

<i>READY BUTTON SELECTED</i>	<i>PRE-FADER CUE SOURCE PRE-DROP-IN</i>	<i>PRE-FADER CUE SOURCE DURING DROP-IN</i>
NONE	TAPE	TAPE**
TAPE	GROUP+TAPE	GROUP*
GROUP	GROUP	GROUP
GROUP+TAPE	GROUP+TAPE	GROUP*

The single asterix indicates that the Supercueing has switched from GROUP+TAPE to the GROUP signal only. When Cues and Monitors are fed with a GROUP+TAPE signal, the two signals are reduced by 3dB to avoid coherent summing. When Supercue switches to GROUP only, the level of the group signal is restored.

#### *IN THE CONTROL ROOM:*

When laying fresh tracks it is possible to monitor either the READY GROUP signal or the READY TAPE signal. The READY GROUP signal allows you to check the signal going to the multitrack. Note that if you overplug another feed into the multitrack send jacks, it is this signal that you will monitor and not that module's Group output.

Remember that you will only hear a signal, when READY TAPE only is selected, if the multitrack is playing, or if the multitrack automatically switches to INPUT when stopped or when in RECORD. It will allow you to hear a "clean edit" (i.e. the sync output of the multitrack prior to the drop-in point and then the group send after the drop in point, switched when the machine switches to input as the track drops into record).

When overdubbing, selecting READY TAPE and READY GROUP together will allow you to hear the artist playing along with the previously recorded track, and then the GROUP signal on its' own after the drop-in point.

#### *IN THE HEADPHONES:*

Let's assume that both READY TAPE and READY GROUP are depressed. This means that the mic is always present in the headphones and allows him (her or even it) to perform along with a previous performance as a warm-up to a drop-in. In other words the artist will always hear himself (or herself etc.) all the time and be fed the sync output up to the drop-in point.

After the drop-in point the TAPE signal is switched off and the GROUP signal (the mic or other source) is raised in level by 3db. This situation allows an artist to pace himself (herself etc.) to the previously recorded track, and in many cases pick up any complex nuances that were in the original performance.

### SMALL FADERS AS EXTRA AUXILIARY SENDS

The INPUT and OUTPUT buttons next to the SMALL FADER provide a means of routing the channel signal into the monitor path in place of the READY TAPE, READY GROUP selections. These two buttons override any READY TAPE or READY GROUP SELECTION. Note that if the Small Fader is in the channel signal path (ie RECORD and VCA TO MON) then these buttons are inactive to prevent howlround. This is very useful during the MIX mode for deriving additional auxiliary sends or clean feeds. These can then be routed to the ROUTING MATRIX and out to effects devices or to cue lines.(eg. Groups 25-32 can be used as clean feeds of a live MIX. The SMALL FADERS being used to send the channel signal to as many of these clean feeds as are required).

<i>Buttons Selected</i>	<i>Source of Monitor Fader Input</i>
INPUT	Pre-Signal Processing but after the Filters if SPLIT
INPUT & OUTPUT	Post-Signal Processing but Pre-LARGE FADER
OUTPUT	Post-LARGE FADER

### MONITOR CUT & SOLO

When laying tracks it is preferable to be able to CUT and SOLO the monitor feeds without cutting the pre-fader cue sends to the studio headphones. This is a different requirement from the MIX status when a channel or monitor CUT must also CUT any sends from the channel. The SSL takes care of these two differing situations automatically:

In RECORD status, monitor cuts do not cut the pre-fader cue sends.

In REPLAY and MIX status, all cuts will cut all the cue sends.

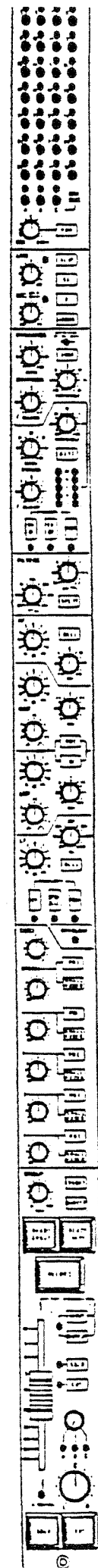
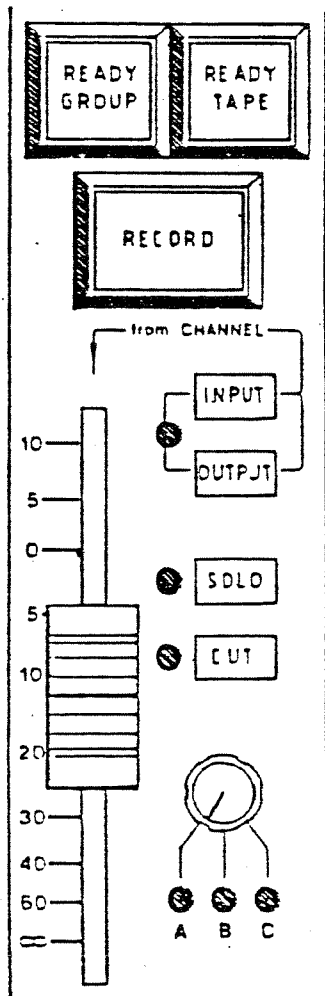

## LARGE FADER (VCA FADER)

The LARGE FADER is usually fed from the CHANNEL INPUT SECTION.

However there are exceptions as this table shows:

<i>STATUS BUTTONS SELECTED</i>	<i>LARGE FADER INPUT</i>	<i>LARGE FADER OUTPUT</i>
MIX	Channel Input	A, B, C Bus Selector
RECORD	Channel Input	Mltrk Routing Matrix
RECORD + VCA TO MON	Monitor Input	A, B, C Bus Selector

If the channel FLOAT button is also pressed:

<i>STATUS BUTTONS SELECTED</i>	<i>LARGE FADER INPUT</i>	<i>LARGE FADER OUTPUT</i>
MIX + FLOAT	Channel Input	Mltrk Routing Matrix
RECORD + FLOAT	Channel Input	Fader Disconnected
RECORD + VCA TO MON + FLOAT	Monitor Input	Mltrk Routing Matrix

The large illuminated SOLO and CUT buttons are always associated with the LARGE FADER.

**SOLO** - This button does not affect the I/O module at all. However it sends a signal to all other modules, which are not Soloed, to cut them allowing the selected channels to be monitored on their own in stereo. This is called destructive solo as it effectively cuts most of the channels and should not be used whilst recording the main outputs. If AFL is selected on the SL 651-V, none of the channels will cut but the selected channel can be heard in mono on the main monitors. Links within each module allow for PFL (Pre Fade Listen) instead of AFL if preferred.

**CUT** - When the VCA Fader is used in the channel signal path the CUT (or MUTE) button actually cuts the channel in two places; at the input and at the fader (VCA). This differs slightly from a cut generated when a SOLO button is pressed on another channel. In this case the channels are only cut at their inputs. This allows the SOLO channel to be heard but doesn't send a cut signal to the VCA and hence the computer. Therefore SOLOs during an automated mix do not get recorded by the computer automation system.

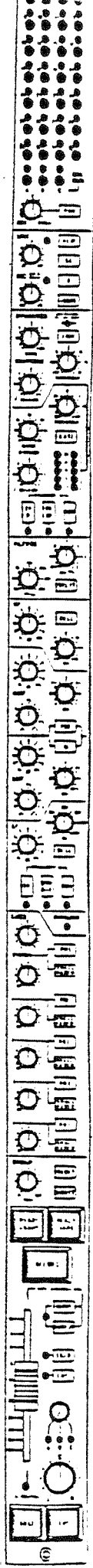
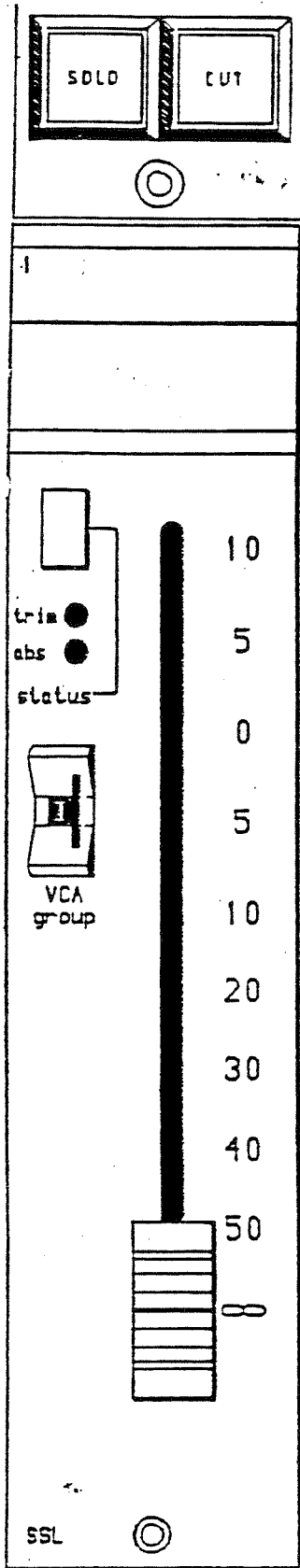

STATUS - The switch beside the LARGE FADER subscribed status, is related to the automation system, as are the trim and abs LED's.

### LARGE FADER VCA SUBGROUPING

The VCA thumbwheel is the means by which the module VCA, being controlled by the LARGE FADER, is also assigned to be controlled by one of the eight VCA GROUP FADERS located at the bottom of the console centre section.

The VCA GROUP FADERS can also be assigned to other VCA GROUP FADERS and so many combinations of VCA subgroups can be achieved.

If a VCA subgroup has been selected then the VCA will be controlled by the LARGE FADER and the VCA GROUP FADER. When at 0 the VCA GROUP FADER has no effect on the channel VCA, allowing 10dB of headroom above this position.

The VCAs are limited in gain so that when a LARGE FADER is at the top of its range the VCA GROUP FADER cannot increase that channel VCA level any further.

When switched to "I" the channel VCA is Independent from the VCA TRIM bus together with any channels not selected to VCA group 0. Hence all modules selected to "I" will be Independent from the VCA TRIM control (located on the 651). This facility is useful when the overall mix is too high in relation to one or more channels. These channels plus any effects returns can then be Independent and the VCA TRIM control lowered to restore a correct balance.

Both the LARGE FADER and the VCA SUBGROUP FADER are connected to the SSL Primary Studio Computer. See the Computer Instruction Manual for further details.

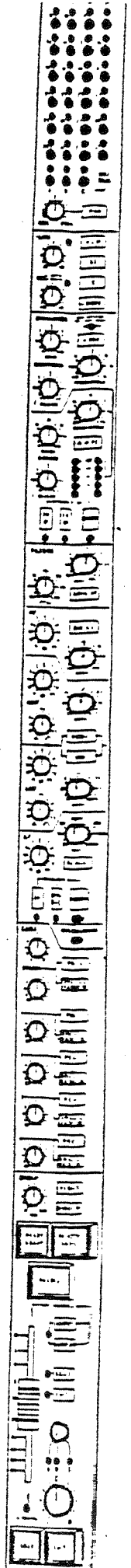
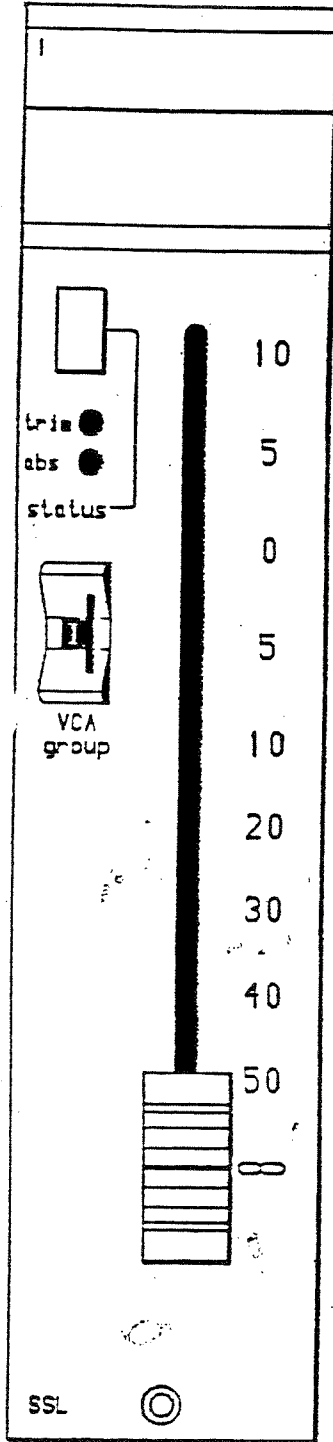

Yet another blank page. Sorry.

## SECTION 4

# THE SL 611-S STEREO CHANNEL MODULE

The Solid State Logic Stereo Input Module was first introduced in 1985 and can be fitted in place of the standard SL 611-V I/O module. Slight wiring differences between the two types of channel modules mean that the mainframe and the patch should be specially prewired to accept the stereo modules.

If the module has been fitted in a frame only wired to accept standard I/O modules then the inputs and insert points will come up on these patch points:

Stereo Module Inputs and Outputs	Standard I/O patch labelling
Line Input L	Mic Input
Line Input R	Line Input
Insert Send L	Insert Send
Insert Send R	Insert Return
Insert Return L	Group Out
Insert Return R	Group Monitor Input

The SL 611-S has comprehensive control facilities to cope with stereo inputs and their routing to the A, B and C Stereo Mix buses and the 32 track routing matrix. Unlike the SL 611-V module there is only ONE signal path through the module hence the routing is far simpler. All signals enter the input section and are then routed via the LARGE VCA FADER to the routing matrix at the top of the channel.

No signal will pass out of the channel to the mix and group outputs unless a destination is selected at the top of the channel.

Total Recall facilities are also available for these modules and the computer automation system works with the FADER and the CUT button in exactly the same way as it does with the SL 611-V I/O modules.

The sections that follow will cover each section of the module in detail starting with the Input section.

Most of the controls will be familiar to you, however there are several sections which are unique to the stereo module which give the engineer stereo control that would otherwise be difficult if not impossible to achieve without such a device.

## INPUT SECTION

The SL 611S is an electronically balanced stereo line input module which will accept a Left/Right or Sum & Difference (M/S) stereo line input.

**GAIN** - Switchable gain control providing +/- 20dB of variable gain in 5dB steps.

**TRIM** - Centre detented, this pot can trim the gain of the input by +/- 5dB.

**BAL** - Centre detented balance control which provides +/- 10dB of variable left/right gain offset.

**O PHASE L** - Reverses the phase of the left input

**O PHASE R** - Reverses the phase of the right input

**MONO L** - When pressed on it's own the left input is sent to both the left and right sides of the channel, cutting the right input to the channel.

**MONO R** - When pressed on it's own the right signal is sent to both the left and right sides of the channel, cutting the left input to the channel.

When both **MONO L** and **MONO R** are selected a mono sum, compensated by a level drop of 3dB on left and right input, of the left and right inputs are fed through the channel.

**M/S** - When selected the left input is assumed to be the sum input (the M signal) and the right input is assumed to be the difference input (the S Signal). A decoding matrix is then inserted which provides the derived left and right signals from the Sum and Difference inputs.

Just for your information the following calculations are used to decode Sum and Difference signals:

$$\text{Sum} = L+R$$

$$\text{Difference} = L-R$$

Therefore from these inputs to derive the left and right signals:

$$L = (\text{Sum} + \text{Difference})/2$$

$$R = (\text{Sum} - \text{Difference})/2$$

This becomes interesting if the matrix is inserted when ordinary left/right signals are present at the input. Try it with reverb returns!

## THE ROUTING MATRIX

Unlike the SL 611-V module the only access to the A, B and C outputs and the 32 track group matrix are found at the top of the channel. The stereo channel signal can be routed to any combination of these outputs, the left signal will route to the odd numbered multitrack groups, right signals to the even groups. Image control of the stereo sends to these groups is covered below in the section on Image Control.

SL611S

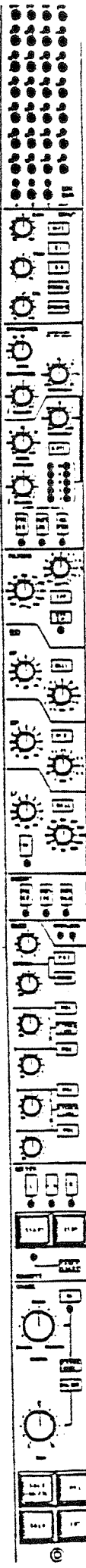
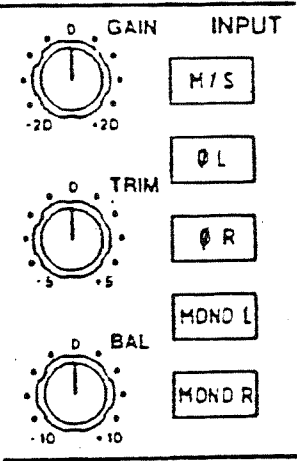
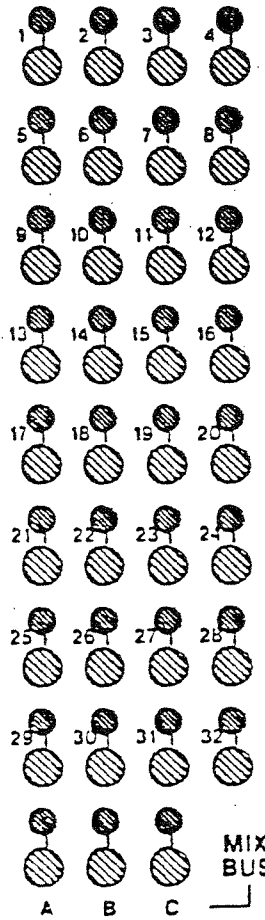

## DYNAMICS SECTION

The Dynamics section is a stereo version of that found in the SL 611-V with similar operational parameters.

The control element in this case is the channel fader VCA so the position of the dynamics section is fixed within the channel.

The Dynamics' side chain, however, can be derived from PRE EQUALISER, POST EQUALISER or from the INSert ReTURn for external keying applications. As there is no GROUP associated with this module other modules cannot directly route signals via the routing matrix to the units side chain. However by routing a signal from another module to an unused group and patching this into one of the insert returns this effect can be obtained fairly easily. This is especially useful for "ducking" stereo music behind vocals or an announcer or for gating such effects as stereo reverb returns.

## STEREO EQUALISER AND STEREO FILTER SECTION

### *FILTERS*

The 12dB/octave high and low pass filters may have a detented off position so that they may be completely removed from circuit if they are not required.

### *PARAMETRIC EQUALISER*

A three band stereo equaliser with carefully matched components allows accurate stereo control of the audio signal. There are three bands each with continuously variable gain and centre frequency controls.

The gain controls each provide +/- 15dB of gain at a centre frequency selected by the frequency pot. As with the mono equalisers in the SL 611-V module, the frequency controls overlap allowing two controls to work together on the same frequency band if required.

The HF and LF section can be switched from a shelving curve filter to a BELL (peaking) type filter using the BELL switch. The MF section has switchable Q factor of 1 or 2 (HI Q).

The following buttons select the position of the filters and the equaliser:

IN - Switches the equaliser into circuit pre VCA.

DYN SC - Switches the Filters into the dynamics side chain for selective compression and gating.

When the filters are switched on with the detented controls they appear directly after the equaliser unless the I/P button is depressed in which case they are inserted at the front of the channel before any of the signal processing or the PRE EQ insert point.

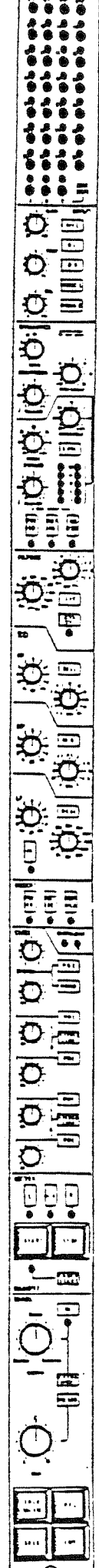
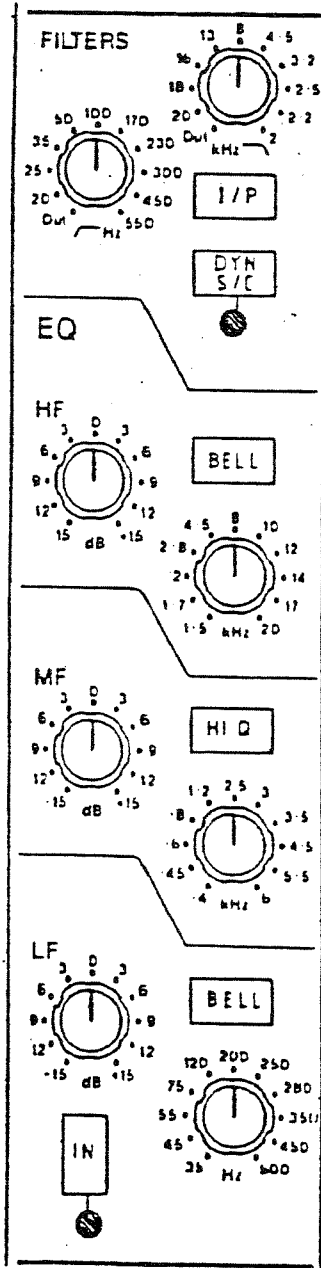
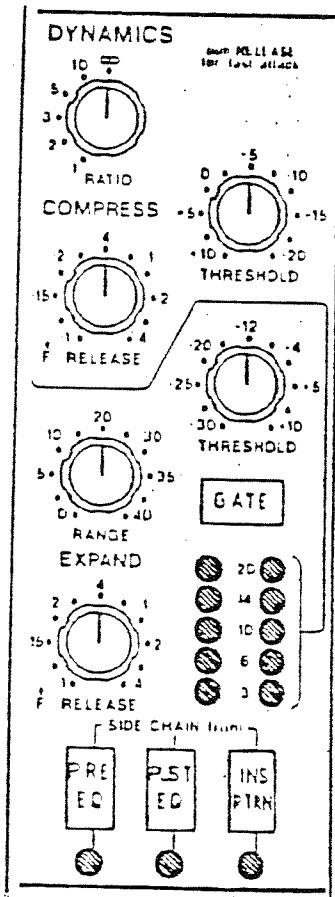

## INSERT POINT

The stereo insert point can be switched to three points in the signal path:

**PRE EQ** - The insert point will appear before the equaliser but post the filters if the I/P button is depressed.

**POST EQ** - The insert point will now appear directly after the equaliser and filter if they have been switched in.

**POST VCA** - Yes the insert point is now after the channel VCA, (not possible with the SL 611-V module) hence after the equaliser and dynamics section (which operates on the VCA).

## OVERLOAD INDICATORS

A pair of overload indicators are situated beneath the Insert switches. These overload detectors monitor signals at four points in the module (channel input, post insert, post EQ and post fader) and indicate when the signal 3dB below the clipping point.

## CUES AND AUXILIARY SENDS

As with the SL 611-V module, six auxiliary buses are available configured as one stereo and 4 mono sends. Each send level control has the SSL standard push/push on/off facility and can be switched pre or post fader. Up is off.

Pre-fader sends are normally cut when the channel is cut. Optionally, links on the motherboard may be set to cut pre fader sends when their channel or assigned VCA Group fader is closed. This is useful when studio floor foldback is being fed pre-fade from one of the auxiliary sends for example. In this case the studio feed will be active from a particular channel until the fader is closed. If a stereo source such as a tape machine is going through the channel unwanted cueing and rewind noises will be prevented from reaching the floor when the fader is closed.

The stereo send (CUE STEREO) routes the left and right signals to the left and right side of the send bus via one single gain control. A centre detented balance control is provided. The MONO button sums the right and the left channels and routes the resultant signal to both sides of the send bus via the balance control which now acts as a pan.

Cue/Aux sends 1-2 and 3-4 normally feed L+R signals to their buses. When the STEREO LINK button is pressed the Left channel signal can be routed to send 1 (and 3) and the right channel signal may be routed to send 2 (and 4) hence configuring sends 1-2 and 3-4 as stereo pairs.

## REMOTE FACILITIES

Two momentary illuminated switches marked START and STOP (controlling relay contacts and reading opto isolated tally returns) provide control of remote external devices such as carts, tape machines, disc players or cue lights. These functions may be assigned to operate as the fader is opened and closed (when the FADER START button has been depressed). Switches on the logic card can be set so that the contacts operate momentarily or latching.

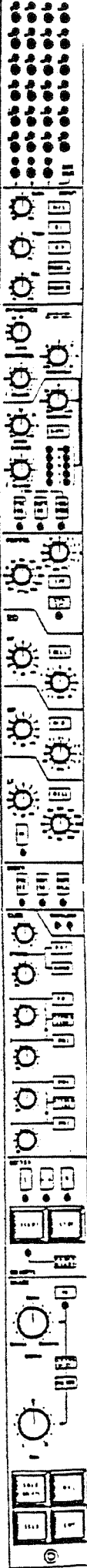
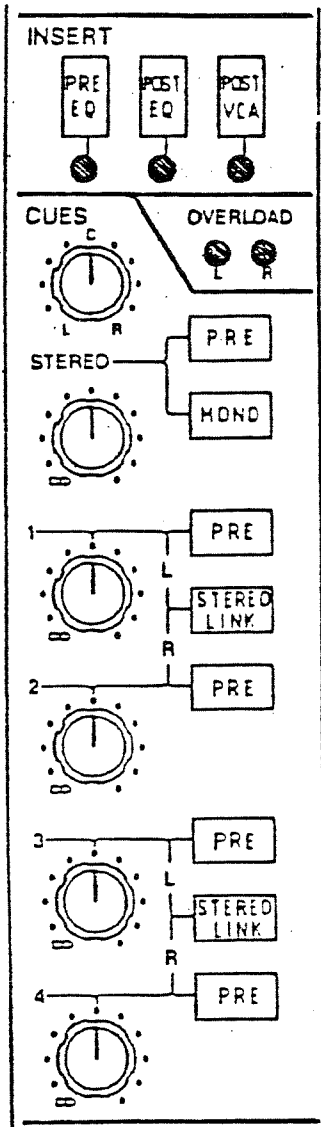

## METER CONTROLS

A single meter above the module can be switched to read either:

- L - left
- >< - automatically reads the higher of the two signals
- R - right

It can also be switched to read the channel VCA fader voltage when the VCA's switch on the SL 651-V is operated.

## IMAGE CONTROLS

Three controls provide a comprehensive stereo image processing system.

**IMAGE WIDTH** - This control varies the stereo image from full width stereo through to mono to a reversed stereo image (L/R reversed). The control has a centre detent in the mono position.

**IMAGE PAN** - The IMAGE PAN pot positions the image thus set across the stereo panorama. On a mono image it provides normal panning; as the image widens, the pan pot's effect diminishes so that it has no effect on a full stereo image.

Using these controls together can provide the engineer with some interesting perspective effects similar to those found on a video mixer. Stereo images may be flipped, collapsed and panned across the stereo image.

**EXTRA WIDE** - The EXTRA WIDE control switches in a width enhancement circuit which expands the image outside of the normal stereo picture.

**FILTER** - The FILTER switch can be used to prevent odd phase anomalies on frequencies below 250Hz when the EXTRA WIDE control is in operation.

**IN** - The whole image processing system is switched into the channel when the IN button is pressed.

**SOLO ISOLATE** - Isolates the channel from the Solo bus. Very useful when the stereo channels are being used as effects returns. When a channel is soloed all channels SOLO ISOLATED will not be muted so that the soloed channel may be monitored with it's associated effects returns in stereo.

**SOLO** - Provides SOLO in place unless the AFL mode is selected on the SL 651-V Master Facilities Module, in which case a mono signal is sent to a separate AFL bus for monitoring.

**PFL** - When operated a L+R (mono) Pre-Fade Listen signal of the channel is sent to the monitors. As an option the channel may be fitted with Fader backstop PFL where the PFL signal may be monitored when the fader is held against its' backstop.

**CUT** - Cuts (mutes) the channel. Connected to the SSL Studio computer (if fitted) as part of the automation system.

## FADER

The fader facilities including VCA grouping and automation are exactly the same as the facilities found on the SL 611-V module.

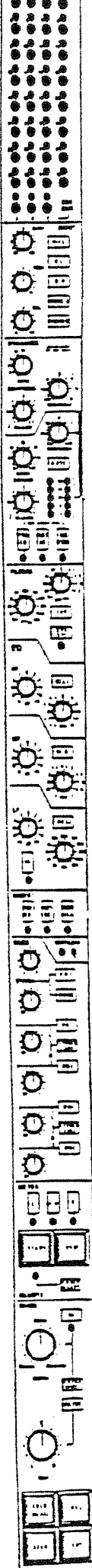
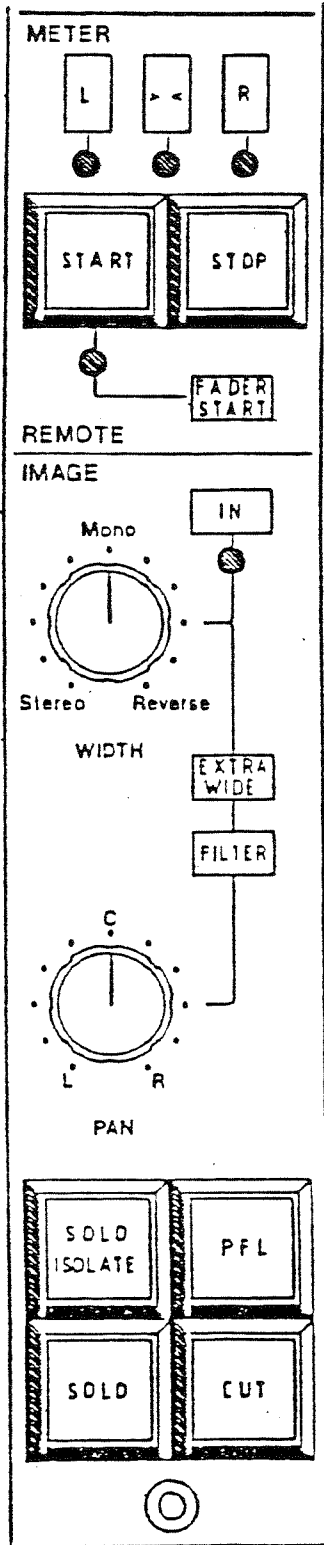



## SECTION 5

### SL 651-V MASTER FACILITIES MODULE

Located to the left of the centre section, the Master Facilities Module houses the master logic controls, monitoring and metering controls, send and echo return masters, communications facilities, power supply rail indicators and a test oscillator.

## POWER SUPPLY INDICATORS

Working from the top of the console downwards the first section you will meet is an array of LEDs which display the present state of the power rails within the console.

The 48 volts supply provides phantom power to the mic lines, and the bipolar 20 volts and the 13 volts supplies are for the audio and logic circuitry respectively.

All LED's should be illuminated, if not then PANIC!

## OSCILLATOR CONTROL PANEL

The oscillator section contains controls for the frequency, level, and the routing of the oscillator to the main group outputs (A,B,C and PRGM) and/or the multitrack groups.

GROUPS - Routes the oscillator to all multitrack output groups and the main A, B and C groups.

OSC TO PROGRAMME - Routes the oscillator to the Programme output.

ON - Switches the oscillator on would you believe. You should ensure that this is OFF during recording to prevent leakage onto the output groups.

The FREQUENCY SELECT knob provides 8 preset frequencies. The LEVEL control adjusts the output level from -25dB to +20dB. When fully anticlockwise a preset level is presented which can be adjusted from the small multiturn pot located to the left of the main level control.

The oscillator feed is available on the patch (jacks L13 and 14) and is normalled to the tone distribution system (jacks M13 and 14). This allows an external oscillator to feed into the tone routing switches above; very useful for those odd frequencies or for pink or red noise.

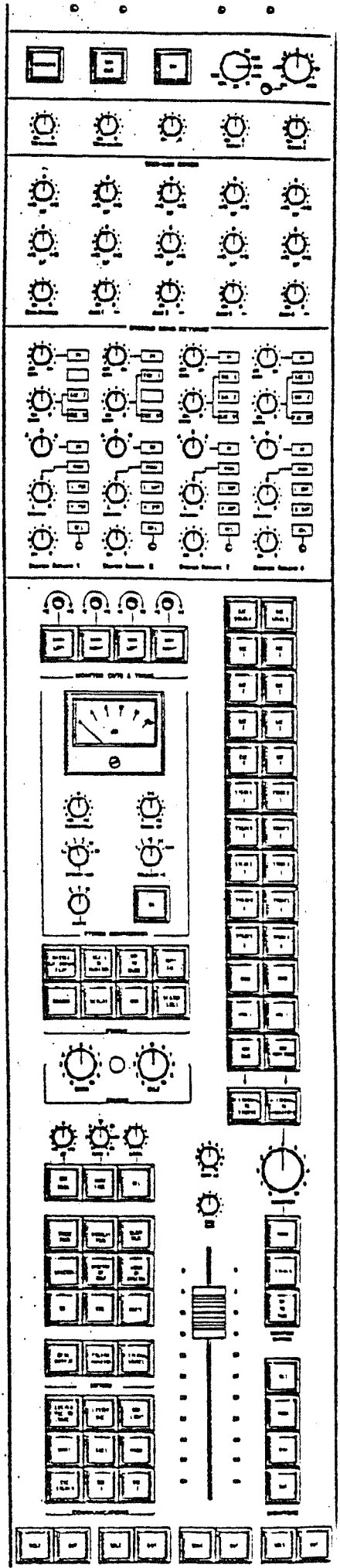
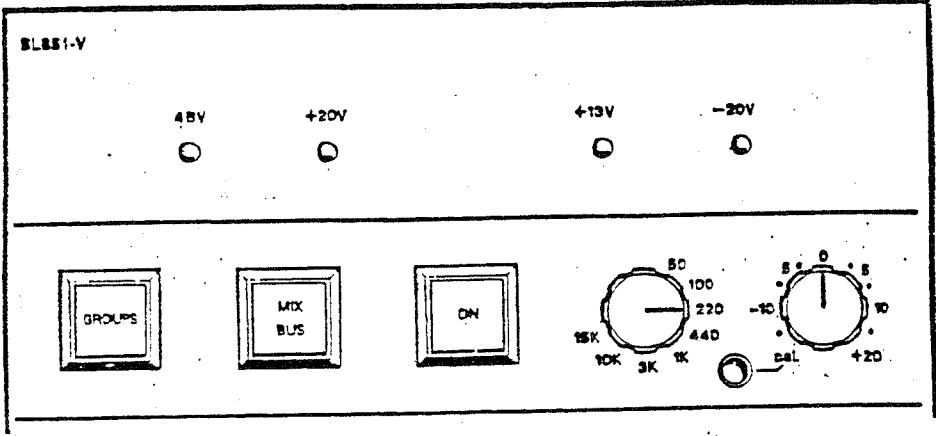

## TALKBACK LEVEL CONTROLS

This panel controls the level of talkback, from the in-built microphone to the studio loudspeaker and headphones, together with level controls for the incoming Listen Mics and the slate level.

**TB TO CANS & TB TO STUDIO** - These level controls feed talkback to the CUES (CUE Stereo, CUE 1 & CUE 2) and the SLS. Note that the talkback is inserted after the Cues and SLS level controls.

3 **SLATE LEVEL** - The slate level control allows the slate to tape via the OMNI button and the LISTEN MIC TO TAPE signal to be adjusted. A low level 30Hz tone is added to the slate signal so that the slate may be located easily at high tape wind speeds.

**LISTEN 1 & 2** - The Listen Mic gain controls have pull-off switches built in. Two listen mics can be placed in the studio and fed into the Listen Mic inputs on the patch. They are mixed through the above level controls and fed into a compressor. The LISTEN MIC button, found in the group of COMMUNICATIONS buttons, allows this signal to be placed on the mini LS whilst dimming the main monitors.

## CUE-AUX SENDS

Each channel is fitted with one stereo and four mono auxiliary sends for use as foldback, echo sends or as mix minus feeds. These master controls allow for final level adjustment together with +/- 15dB of HF (10Khz) and LF (100Hz) equalisation.

Auxiliary sends 1 to 4 appear on the patch N1-4 where they are normalled to the outgoing jacks P1-4 to be used as feeds to effects units.

Aux 1 and 2 together with the Stereo send are simultaneously fed back into the communication section of the Master Facilities Module where talkback (via the buttons in the COMMUNICATIONS SECTION), stereo reverb (via the Echo Returns) and external stereo feeds (via the EXTERNAL TO STUDIO selector) can be added.

Three Stereo Cue Outputs then emerge on the patch N9-14 for use as headphone foldback. Note that Cue Stereo is derived from the Stereo send on each channel, Cue 1L & 1R are derived from AUX 1 and CUE 2L & 2R are derived from AUX 2.

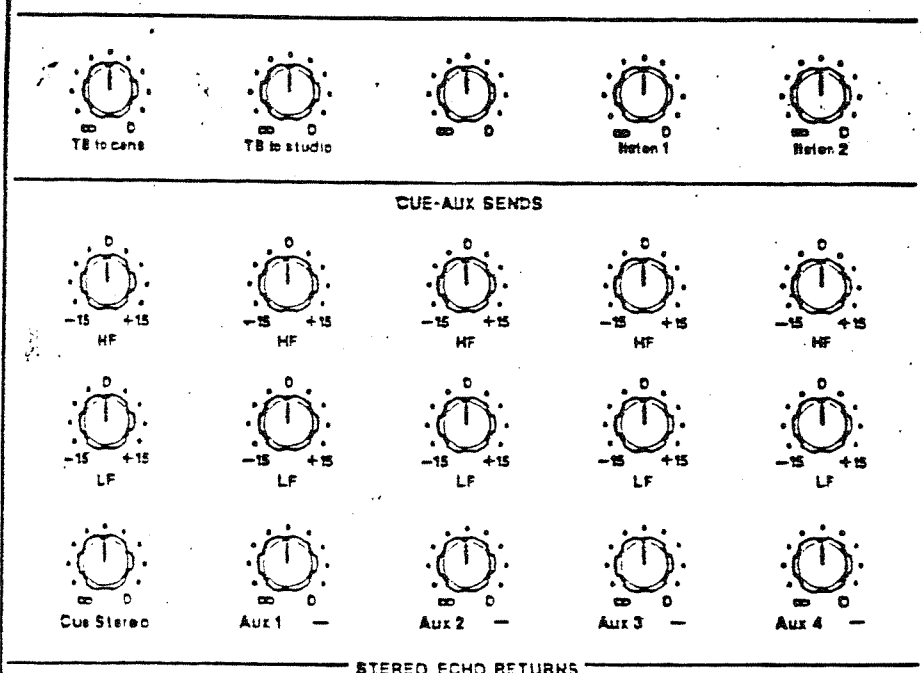

STEREO ECHO RETURNS

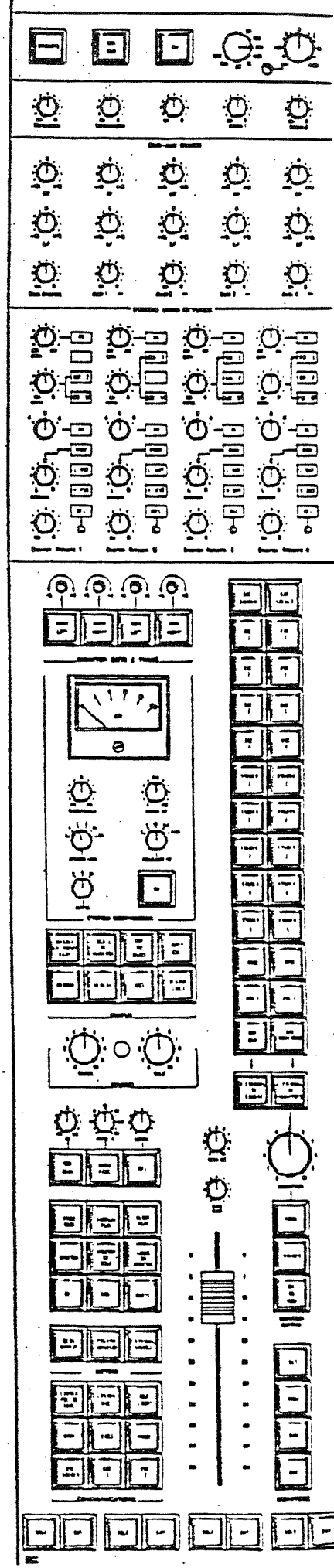

## STEREO ECHO RETURNS

The four stereo echo returns are designed to be driven by the returns of devices which have been fed from the corresponding mono aux buses described above.

**SPIN** - The spin control sends that return back to its' corresponding send when the IN button is latched. Example: The spin control on STEREO RETURN 4 will feed a mono sum of the return into the AUX 4 bus .

**CANS** - This level control, and the buttons associated with it, allow the return to be routed to the other CUE sends for reverb on foldback.

**A B C** - Allows the return to be routed directly to the A, B or C mix bus.

**L/R PAN** - When up the BALANCE control will balance the return. When pushed in the inputs are monoed and the balance control now acts as a pan control. Very useful when you have a mono return, such as a delay line, as it saves having to parallel the inputs on the patch.

**L CUT** - Cuts the left return input.

**R CUT** - Cuts the right return input.

**AFL** - Feeds the stereo return to the AFL bus and switches the bus output to the main monitors via the AFL level control.

The **STEREO RETURN** control at the bottom of this section controls the level of the return to the A, B or C mix bus, whichever is selected above.

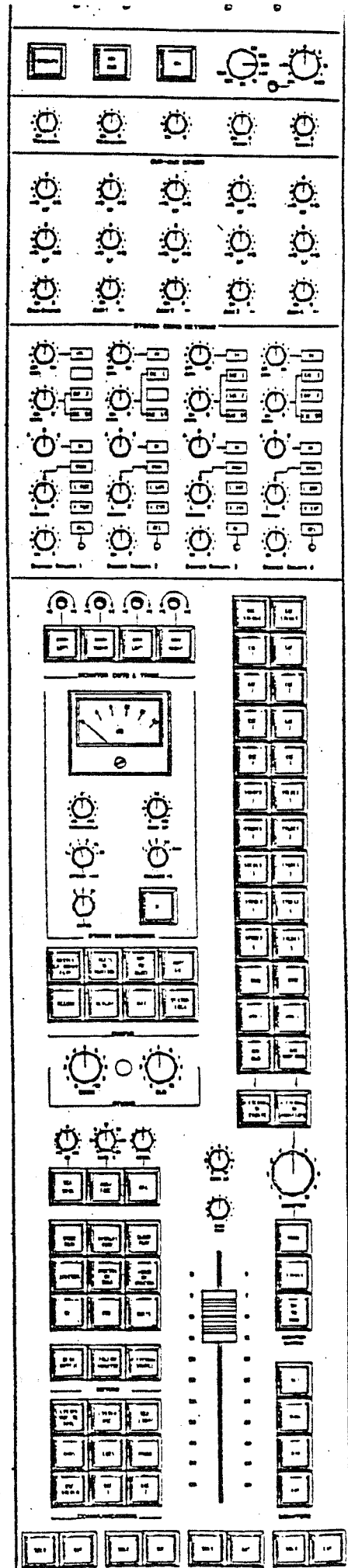
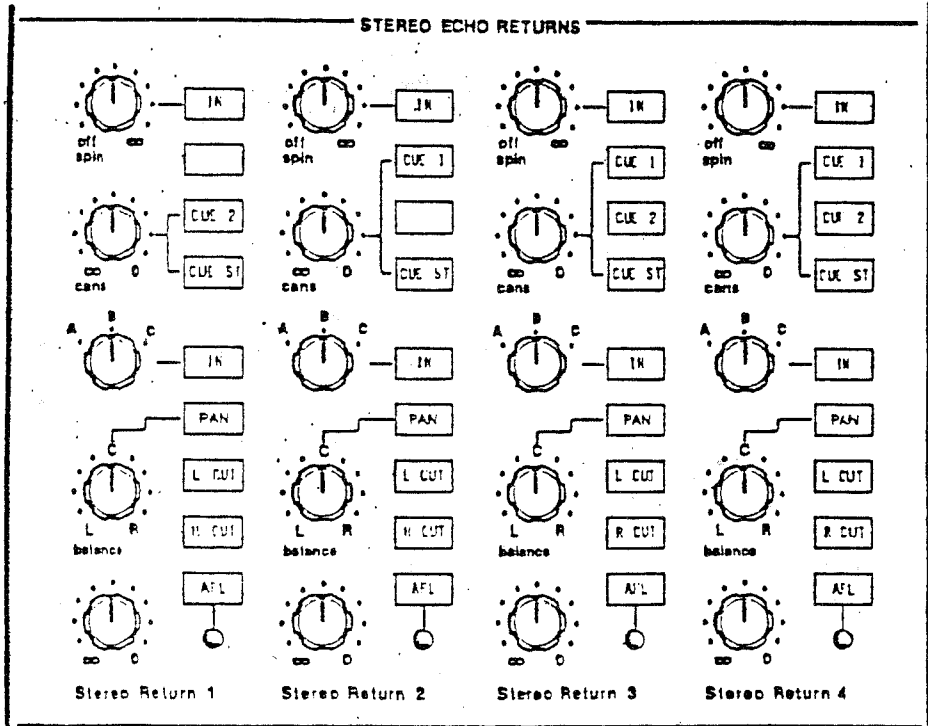

## CONTROL ROOM MONITOR SYSTEM

### *MONITOR CUTS AND TRIMS*

Two separate control room loudspeaker outputs are provided for the MAIN monitors and for a second pair of speakers designated MINI LS. These can be muted individually with the four cut switches. The multiturn pots mounted above these switches allow for speaker centring with +/- 3dB of gain offset.

### *MONITOR SELECTION AND CONTROL*

The large rotary knob, marked MONITOR, controls the level of the MAIN control room monitors. This is usually fed from the PROGRAM output but alternative sources may be fed to the monitors by operating the EXTERNAL TO MONITOR button. This button routes whichever source on the 13-way row of switches, mounted immediately above, has been selected.

The group of buttons labelled MONITOR MATRIX control the mono matrix circuits:

MONO - Sums the left and the right monitor bus and feeds this equally to both left and right monitor outputs. ie. Mono. Note that this tends to narrow the stereo image somewhat.

MONO L - Cuts the right monitor bus and feeds the left bus signal to both outputs. (Extremely useful when trying to monitor a VTR with SMPTE on the right audio channel!)

MONO R - The same as above but with the right feed monoed to each output.

The MONITORS buttons below:

ALT - We provide this switch to switch the MINI LS (or MAIN) feed to a third pair of speakers via an external relay box. This switch may or may not be wired in your studio to select the third pair of speakers from either of the speaker outputs.

MINI - When depressed this sends the monitor bus to the mini LS output via the MINI LS pot.

DIM - The DIM button dims both speaker outputs to a level preset by the DIM LEVEL pot. The DIM circuit is automatically activated when any of the following buttons are pressed:

LISTEN MIC, CUES, CUE STEREO, CUE 1, CUE 2, MD, Oscillator TO PROGRAMME and GROUPS.

CUT - Cuts whichever pair of monitors have been selected. Activated automatically by pressing the OMNI or the LISTEN MIC TO TAPE buttons.



## STATUS BUTTONS

This group of buttons is extremely important as they control the routing paths within the I/O modules. Four different status configurations can be obtained. They are described in detail in section 2. Briefly, the modes are:

**RECORD** - Basically this mode is for recording sources to the multitrack machine. It switches all channel inputs to Mic and the Multitrack machine to sync. These inputs are then routed, via the LARGE FADERS, to the multitrack routing matrix and thus to the multitrack. The SMALL FADERS take the multitrack returns and/or the group sends (depending on the READY GROUP and READY TAPE buttons) and feed these to the main output buses for control room and cue monitoring.

**REPLAY** - Same as for RECORD but switches (if connected) the multitrack to the replay head and all SMALL FADER inputs to TAPE (overriding any GROUP selections) thus allowing for quick monitor mixes of the recorded tracks to the main outputs.

**MIX** - This status switches (if connected) the multitrack to the replay head. All channel inputs are switched to line to take the multitrack returns to the LARGE FADERS and then to the main A, B and C output buses for remixing. The SMALL FADERS take their input as before but are now routed to the multitrack routing matrix and can be used as additional inputs to the mix (the routing matrix at the top of each channel allows these faders to feed to the groups and to the main A, B, and C output buses). They can also be used as additional inputs which can be subgrouped via the routing matrix or as additional stereo or mono sends from each channel.

**MIX and RECORD** - When the MIX and RECORD buttons are pressed together the multitrack switches to sync for overdubbing. All channels behave as if they were in the MIX mode unless a module's READY TAPE or READY GROUP BUTTON is pressed, which makes that particular channel behave as if it were in the RECORD mode for overdubbing tracks.

The additional buttons within this section function as follows:

**MASTER CH INPUT FLIP** - Flips all channel inputs between mic and line.

**VCA's TO MON** - In RECORD or REPLAY mode, this flips the small and LARGE FADERS so that the SMALL FADERS feed sources to the multitrack routing matrix and the LARGE FADERS are used for the monitor mix to the A, B and C buses.



## STATUS BUTTONS Continued

MIX TO CUES - Provides an easy way of sending the program bus to the cue sends via the CUES rotary level control. This button replaces whatever was on the Cue send bus' with the stereo program feed unlike the EXTERNAL TO STUDIO button which is additive. This may be useful at the beginning of a session to provide a quick workable mix to headphones, while spending some time sorting out the finer points of the cue feeds in the control room.

AUTO CUE - This is an autocueing system which is very useful in the drop-in situation. Talkback and optionally the listen mics, which are normally non-latching, can be latched on for constant two way communications purposes and are automatically switched off when the multitrack machine is in PLAY or RECORD.

STATUS LOCK - For use in Broadcast or Live applications when changing status' would cause havoc! This button disables the following buttons:

STATUS BUTTONS - RECORD, MIX & REPLAY. VCA's TO MONITOR  
MASTER CH INPUT FLIP  
OSCILLATOR ON  
OMNI TALKBACK  
LISTEN MIC TO TAPE  
AUTO CUE

SOLO is inhibited and AFL is selected. RED LIGHT is switched on. SLS is disabled.

## VCA TRIM, AUTO FADE & AFL

VCA TRIM - The button switches in the VCA TRIM control above. This raises or lowers the level (by +/- 15dB) of all VCA faders (except the main Programme VCAs) selected to "0" on their thumbwheel switch. Position "I" (Independent) disables the trim effect on the fader if it has not been selected to a VCA Group.

AUTO FADE - is an automatic fade in/out operating on the main program VCAs. It will fade up, or down, the main fader over a period of time specified on the control above. This can vary from 1-60 secs and is recorded by the computer automation system if this is fitted. When the button is pressed, the fade down will start. After fading out the master fader will start a fade up, at the same rate, as soon as the button is released.

AFL - When AFL is selected the normal SOLO mode is overridden and pressing a SOLO button will now send an After Fade Feed of the selected channel or monitor signal to the separate AFL bus and on to the main monitors. This allows for non-destructive monitoring of the selected signal. The AFL signal will be mono if derived from an I/O module. Stereo AFL is provided for signals from the SL 611-S Stereo modules and the SL 688-V panel.

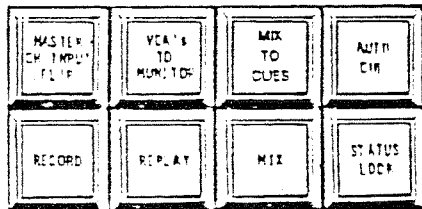

STATUS

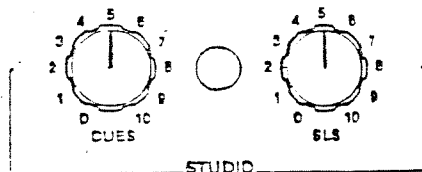

STUDIO

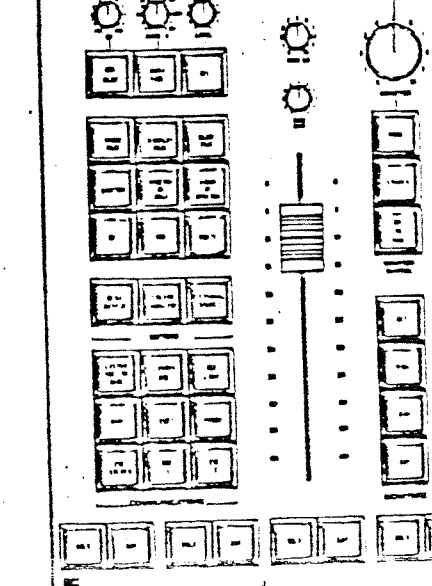
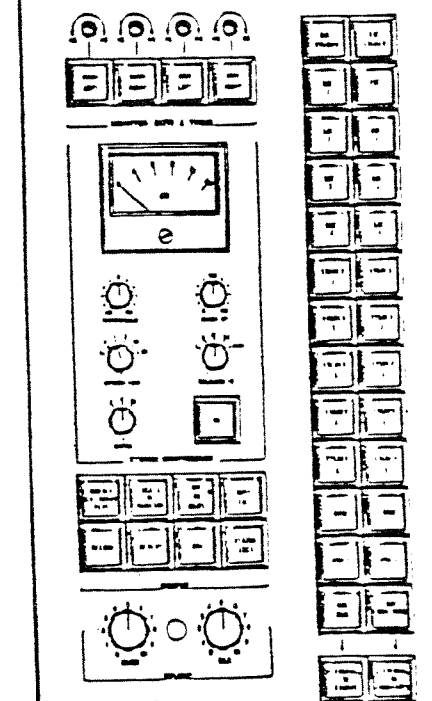
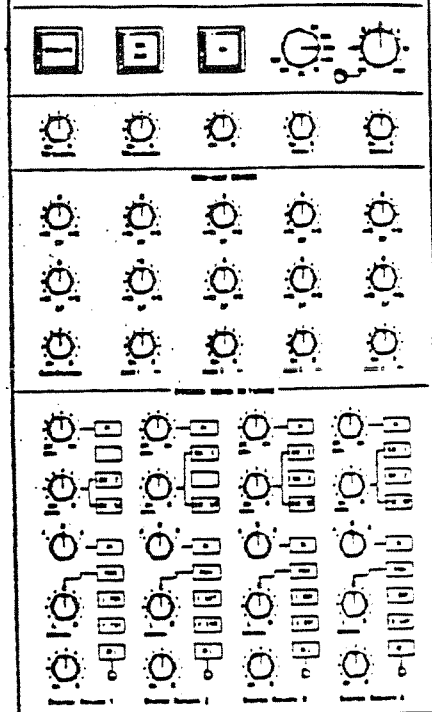
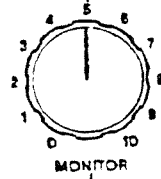
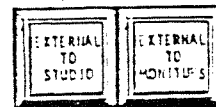
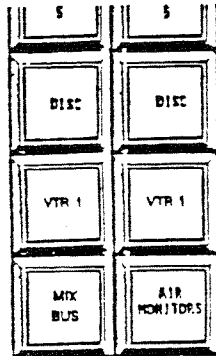
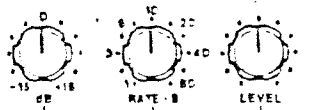

## PLASMA BARGRAPH CONTROLS

These buttons are only found on consoles fitted with Plasma meters. If Plasma meters are not fitted then only the VCA's button is used, the other 8 buttons are free for use by the studio for special custom functions.

A peak storage facility is built into the Plasma meter system. Each meter has two plasma displays; one side is used for the PPM or VU level reading and the other for the stored peak level reading.

**STORE PEAK** - The peak level reaching each meter is stored whenever this button is depressed.

**DISPLAY PEAK** - When operated the peak levels stored by the STORE PEAK button are displayed next to the Group/ Tape level reading. This is updated so long as the STORE PEAK button is latched.

**CLEAR PEAK** - Clears the STORE PEAK and hence the DISPLAY PEAK if this has been selected.

The Plasma meters have a built in, third octave, 15 band, stereo, spectra display of whatever signal is being metered by the main stereo meters. Note that on consoles with a frame size of less than 32 modules, a mono spectrum is displayed.

**SPECTRA** - Selects the spectrum display.

**SPECTRA ON SOLO** - A really useful feature which allows the meters to show Group/Tape levels until a SOLO button is pressed. When this happens the spectrum display is automatically switched on to allow you to monitor the spectral content of the SOLOed channel(s). eg. The vocalist sounds very middley so you SOLO the channel and equalise out the peak whilst referring to the spectral display. Awesome.

**+10dB ON SPECTRUM** - Used to increase the gain of the spectral display. This is often required when using the SPECTRA ON SOLO facility to allow sufficient level from a single module to drive the spectral display.

**PPM** - Selects Peak Programme Meter ballistics and scale.

**VU** - The meters will act with VU ballistics and scale.

**VCA's** - The meters will now display the levels of the channel VCA's. This is very useful during mixing as these meters can now supplement the computer bargraph display. If VU or mechanical PPM meters are fitted the VCA's button similarly allows the meters to indicate the channel VCA levels as described above.

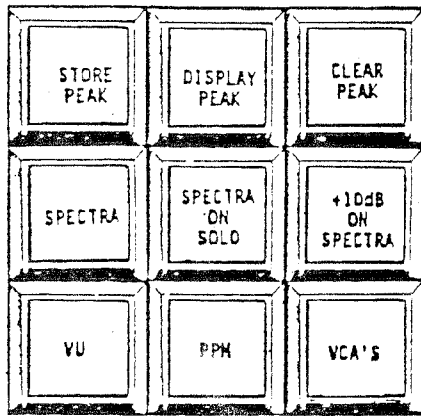

4 5

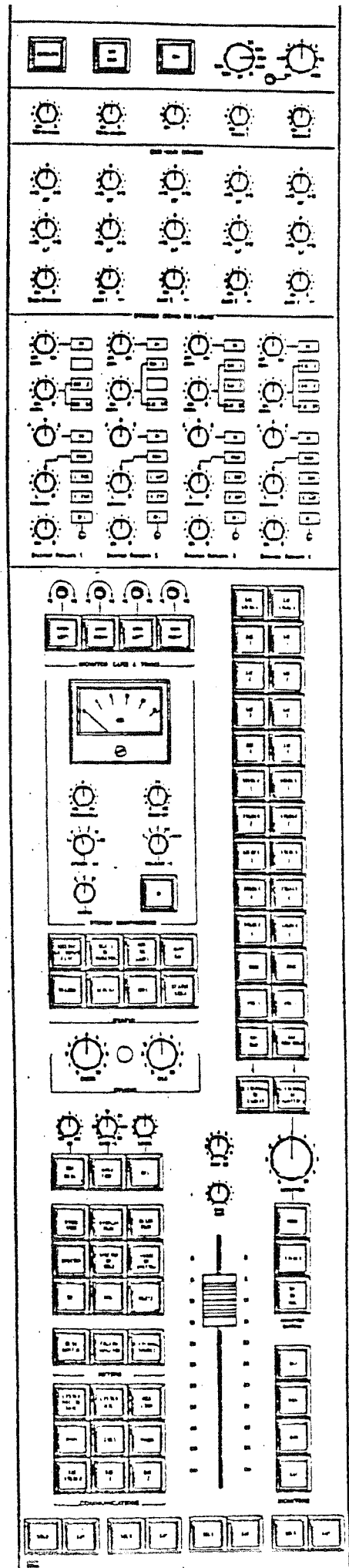

## STEREO METERS

These buttons assign signal to the the main program stereo meters.

**DESK OUTPUT** - Selects the Programme output to the main meters.

**FOLLOW MONITOR** - Whatever has been selected to the monitor loudspeakers will be displayed on the main meters.

**EXTERNAL SOURCE** - The main stereo meters will display whichever external source button (the 13 buttons above the EXTERNAL TO MONITORS button) is selected irrespective of whether it is being monitored. eg. The main stereo programme can be monitored whilst the meters read the return from the stereo tape recorder recording the output as a check. This facility is also useful for metering the Cue sends if the main meters are not required for metering the programme output.

## COMMUNICATIONS

The group of switches marked COMMUNICATIONS control the switching and routing of the talkback and listen systems briefly described on the previous page, as well as controlling the operation of the RED LIGHT.

**LISTEN MIC** - Feeds the listen mics to the small LS dimming the main LS.

**LISTEN MIC TO TAPE** - Feeds the Listen mics to multitrack and main output groups. Cuts the main monitors.

**RED LIGHT** - Provides isolated contact closure for hooking up to a studio Red light or Transmission light via an external relay box. When AUTOCUE button is on the red light can be activated automatically when the multitrack goes into Record. (Internal links can be set to select this option from machine PLAY or RECORD)

**M.D** - Switched talkback which appears on the patch N41 for use as an additional TB send to the Musical Director, the studio floor or to the machine room.

**OMNI** - Cuts all loudspeakers and feeds the Talkback Mic to Multitrack, A,B,C, PRGM, Cue sends and Studio LS. A low level 30Hz tone is mixed in with the signal to tape so that the slate may easily be located at high wind speeds by listening off the heads.

**CUES** - Feeds talkback mic to Stereo Cue, Cue 1L & 1R and Cue 2L & 2R.

**CUE STEREO, CUE 1 and CUE 2** buttons send talkback to their respective outputs.

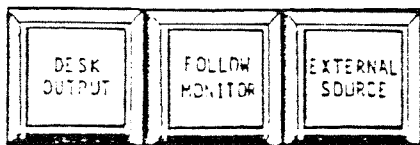

METERS

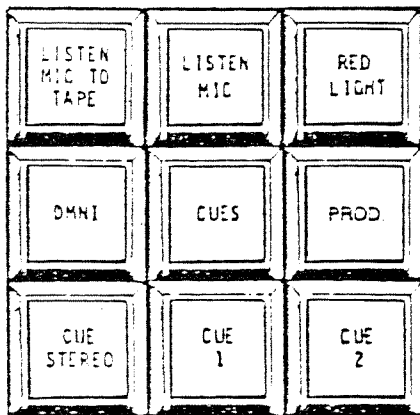

COMMUNICATIONS

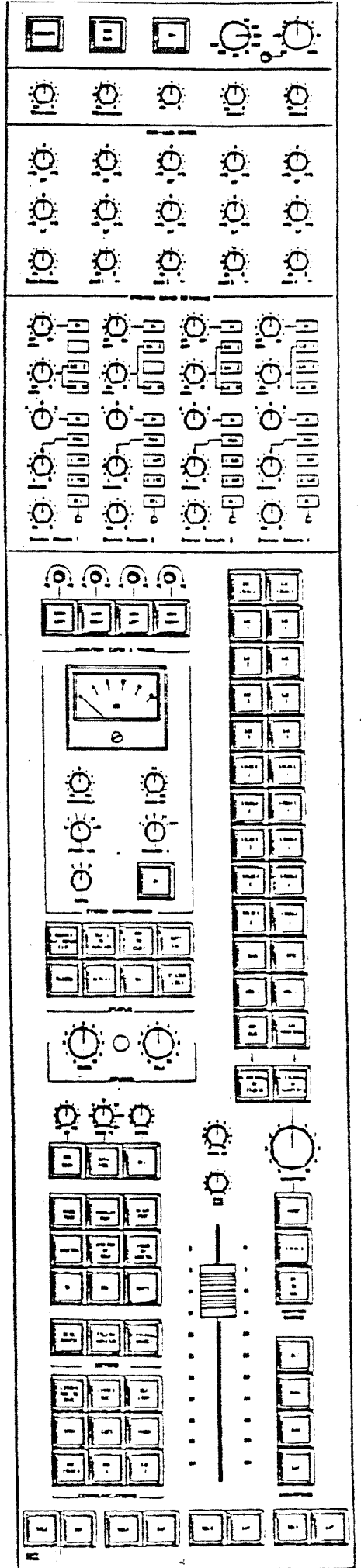



## SECTION 6

### THE SL 688-V STEREO MIX MATRIX PANEL

Section 2 covers general signal flow through the panel whereas this section looks at each control in detail.

As with section 2 it is probably best to divide the signal flow of the panel into the four sections and add a fifth section to cover the master controls:

1. A, B, C Groups and their outputs.
2. The Programme feed
3. The Monitor feed
4. The Tape return section.
5. The Master Controls

#### 1. A, B, C GROUPS AND THEIR OUTPUTS

**GROUP & MONO TRIM POTS** - Signals arriving from the modules go straight into the GROUP TRIM CONTROLS and then pass through the insert points. Each of the A, B and C Local Control sections contains two trim pots, one marked GROUP and the other marked MONO TRIM.

The GROUP pot trims the gain of the stereo mix bus amps, with a range of +10dB to minus infinity. There is a centre detent at the unity gain position. These pots allow the engineer to individually adjust the levels fed to the 8 and 4 TRACK machine outputs.

The MONO TRIM pot is a sub-trim following the GROUP trim pot, providing further control over the level presented to the 4 TRACK outputs. These outputs are derived by summing the left and right channels of the A, B and C 8 TRACK buses. The controls have a range of unity gain to -12dB, with a centre detent at the -6dB point. This arrangement ensures that an equal in-phase level provided to the left and right buses of the 8 TRACK feed will appear on the 4 TRACK output at the same level.

**STEREO MIX BUS ROUTING** - Three additional buttons are provided in each of the A, B and C Local Control sections.

Selection of the A TO PROGRAMME routes the A Mix Bus to the Programme Mix Bus (Main Stereo Output). B and C TO PROGRAMME similarly route the B and the C Bus outputs to the Programme Mix Bus. Obviously, these buttons may also be used to de-select any of the individual mix buses from the Programme Mix Bus, providing a "CUT TO PROGRAMME" function.

The two additional buttons in each section allow you to route that section's mix to either or both of the other mix buses. This feature allows quick setups of mix and mix minus feeds. For example, if the A TO B is selected, the B bus output will contain every signal on the A bus plus any signals routed directly from the modules to the B bus. The further selection of the B TO C bus would result in the C bus output containing all signals present on the A and B buses, plus any additional signals routed directly from the I/O modules to the C bus. Electronic logic prevents illegal combinations such as A TO C plus C TO A, which would result in feedback loops.

## 2. THE PROGRAMME FEED

**THE PROGRAMME FROM BUTTONS** - There are three PROGRAMME FROM BUTTONS.

**A+B+C** - When selected the A, B and C Mix buses can be selected to the Programme Mix by operating the local A, B, and/or C TO PROGRAMME buttons. These buttons can also be used to deselect its' mix bus from the programme Feed.

**8 TRACK MONITOR** selects the 8 track tape monitor section to the Programme bus.

**4 TRACK MONITOR** selects the 4 track tape monitor section to the Programme bus.

It is also possible to select PROGRAMME FROM A+B+C and either the 8 TRACK or 4 TRACK simultaneously. In this case, the A+B+C feeds will be combined with the 8 or 4 TRACK source, or any other line level sources patched into these machine returns (jacks P15-26. see section 8 THE PATCH). In other words the SL 688-V panel can serve as a mixer for the three stereo console buses plus three additional stereo sources. To facilitate this function provision has been made to alter the placement of the SL 688-V stereo faders in the signal path.

The selected sources are then fed into the SL 651-V Master Facilities module where they pass through the Master VCA which is controlled by the Master Fader and the Stereo Programme Compressor.

The AFL button routes the signal present at the output of its' fader to the control room monitors (non destructive stereo After Fade Listen). If the faders are out of circuit then the AFL button will pick up the post-Group Trim stereo feed of the A, B or C buses when the A+B+C button is selected. If the 4 or 8 TRACK section has been selected then the AFL button will select the output of the TAPE/GROUP switch.

## 3. THE MONITOR FEED

There are three MONITOR FROM buttons.

**PROGRAMME** - When selected, the monitors follow the PROGRAMME FROM selection. Two additional buttons allow the operator to monitor from the 8 TRACK or the 4 TRACK section without disturbing the programme feed.

The selected monitor feed leaves the SL 688-V panel and passes to the Master Facilities module where LS selection and level control facilities are found.

THE SL688V MIX MATRIX PANEL

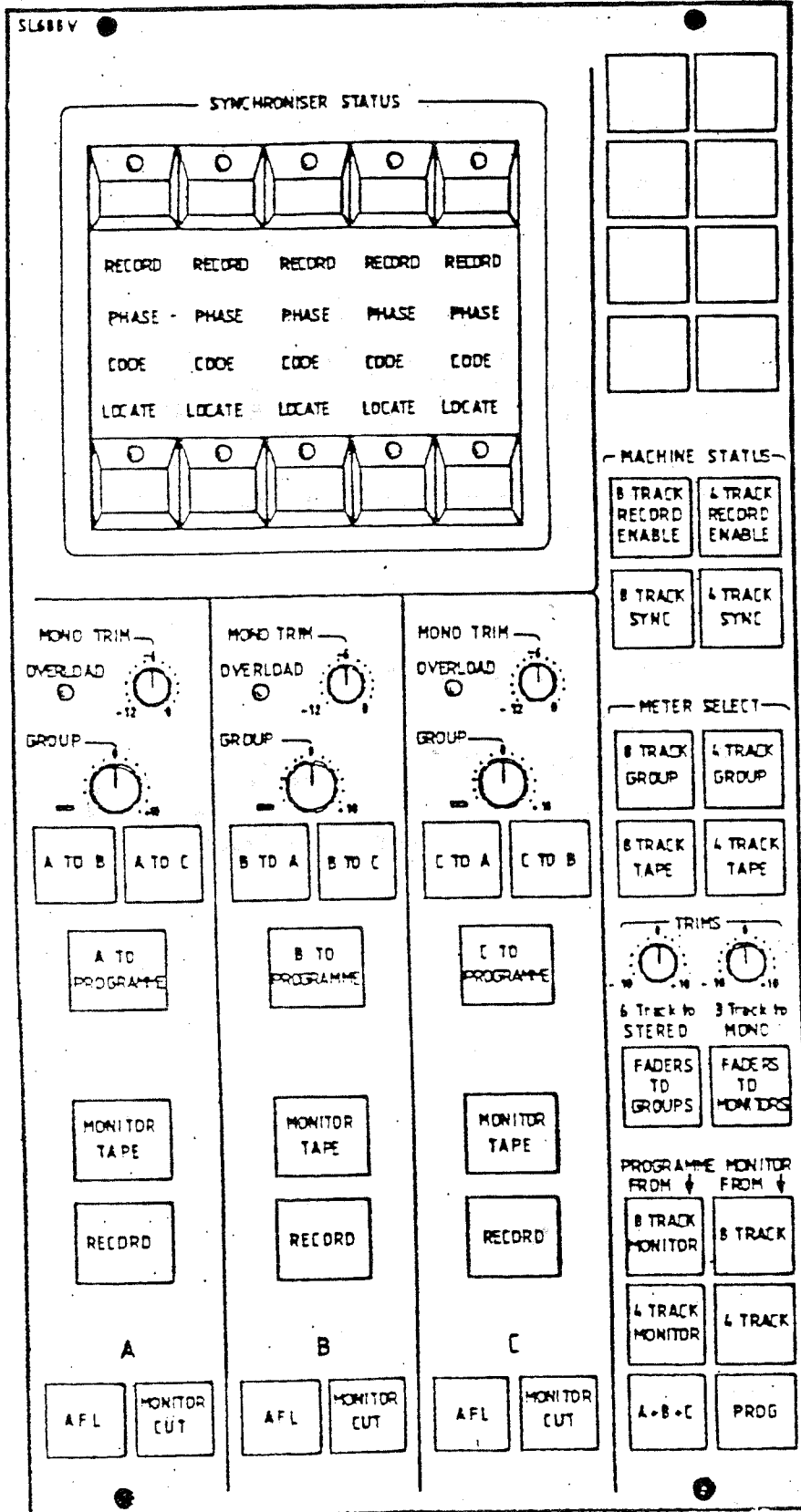

#### 4. THE TAPE RETURN SECTION

Provision has been made for two separate tape returns; the 8 TRACK and the 4 TRACK sections. In fact they consist of 3 stereo or 3 mono tape return inputs, switching between the Group output and the Tape returns, and controls for mixing these down to the Programme or Monitor buses. This allows for quick level matching between Tape and Group signals before punching into record.

**MONITOR TAPE BUTTONS** - When monitoring or taking the programme from the 8 or 4 TRACK it is possible to flip each of the A, B and C tape return buses between the Group send and the Tape return using the TAPE MONITOR buttons.

When none of these buttons are selected, the group bus output of each section is fed to the output. Selection of one or more MONITOR TAPE buttons replaces the group bus output with the tape return inputs.

The MONITOR CUT button follows the Tape/Group switches on each tape monitor bus.

If FADERS TO MONITORS has not been selected the returns are mixed on a 1 to 1 basis. The signal then passes through the TRIM control, labelled 6 TRACK TO STEREO to control the level of the 8 TRACK returns (and the 3 TRACK TO STEREO to control the 4 TRACK returns) which feed the Programme or Monitor buses.

THE SL688V MIX MATRIX PANEL

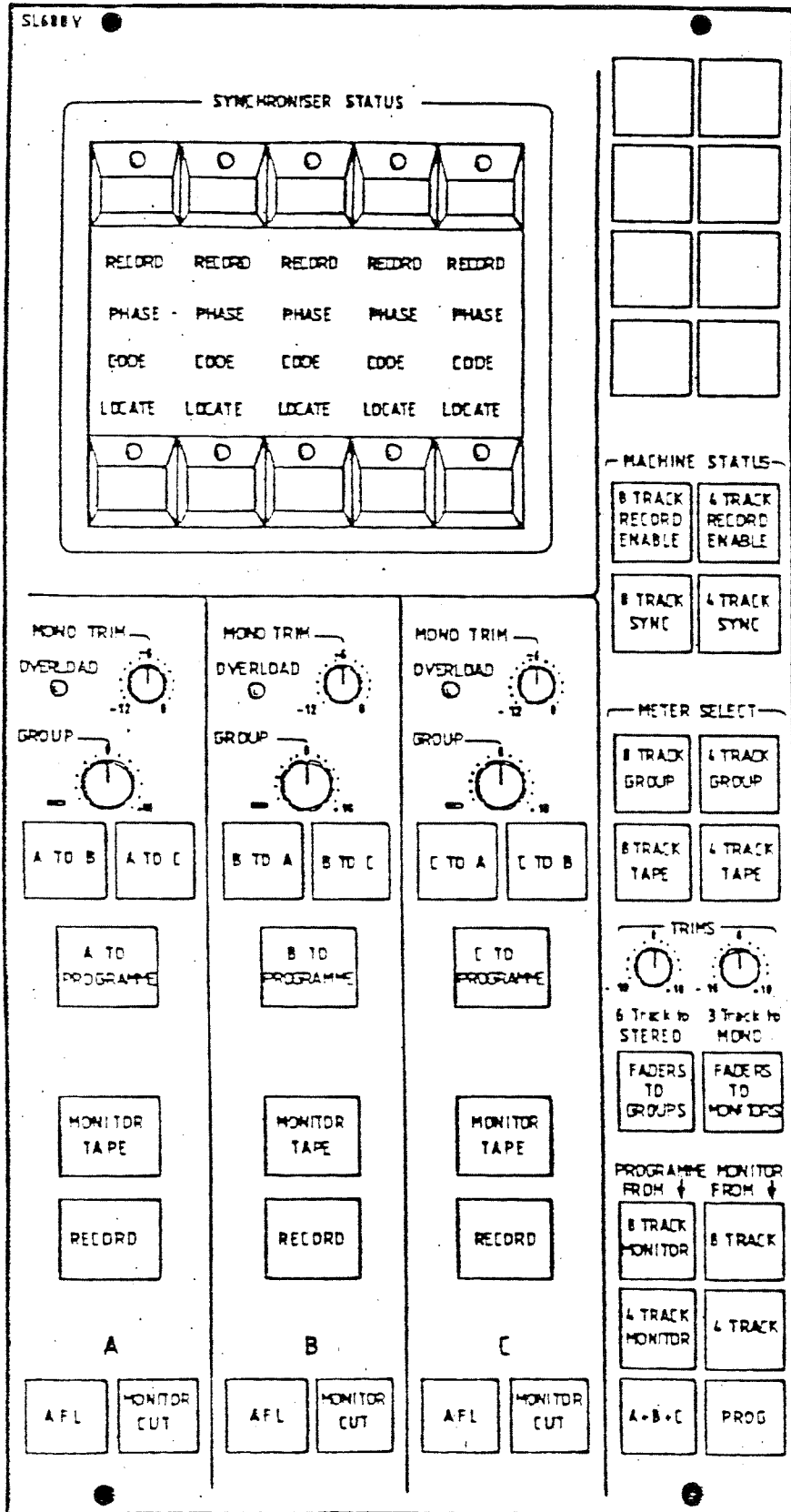

## 5. THE MASTER CONTROLS

The RECORD buttons are momentary, electronically latching push-buttons which are further interlocked with the the 8 TRACK and 4 TRACK RECORD ENABLE Machine Status Buttons. Each of the A, B and C buses has its' own button.

The RECORD buttons for the A mix bus sets tracks 1 & 2 of the 8 track master (and/or track 1 of the 4 track master) to RECORD. Similarly, the B RECORD button selects RECORD for tracks 3 & 4 of the 8 track (and/or track 2 of the 4 track machine), and the C RECORD button selects RECORD for tracks 5 & 6 of the 8 TRACK (and/or track 3 of the 4 TRACK machine).

As mentioned, the SL 6000 E accommodates mono and stereo operations, either separately or simultaneously. The 8 TRACK and 4 TRACK RECORD ENABLE buttons determine which tracks will be set to RECORD status by the Local Controls. Additionally, 8 TRACK and 4 TRACK SYNC buttons are provided to switch the designated machine's output from Repro to Sync.

All Machine Status buttons are provided by SSL for connection to external machines by your studio technicians. These buttons can, and were designed to, be used with an 8 TRACK and a 4 TRACK machine for recording Music, Effects and Dialogue. However there are many other machine combinations, including 3 and 6 stripe mag machines, 16, 24 or 32 track recorders, or even 6 tracks of the main multitrack machine, which could be hooked up to the controls. We suggest that if other machines are connected then the buttons should be relabelled to indicate the correct type of recorder.

METER SELECT BUTTONS - Four possible signal sources may be selected within the SL 688-V panel. These are:

8 TRACK GROUP, 8 TRACK TAPE, 4 TRACK GROUP, 4 TRACK TAPE.

Four correspondingly labelled buttons, situated in the upper right corner of the panel, allow the engineer to make the selection.

When none of the buttons are selected, the meters on the console penthouse will follow the monitor selection made by the SL 688-V Master Mode Controls, and local Group/Tape monitor selection.

Pressing any Meter Select Button will override the FOLLOW MONITOR mode, locking the meters to the selected source. thus it is possible to monitor any source while metering any other source.

# THE SL688V MIX MATRIX PANEL

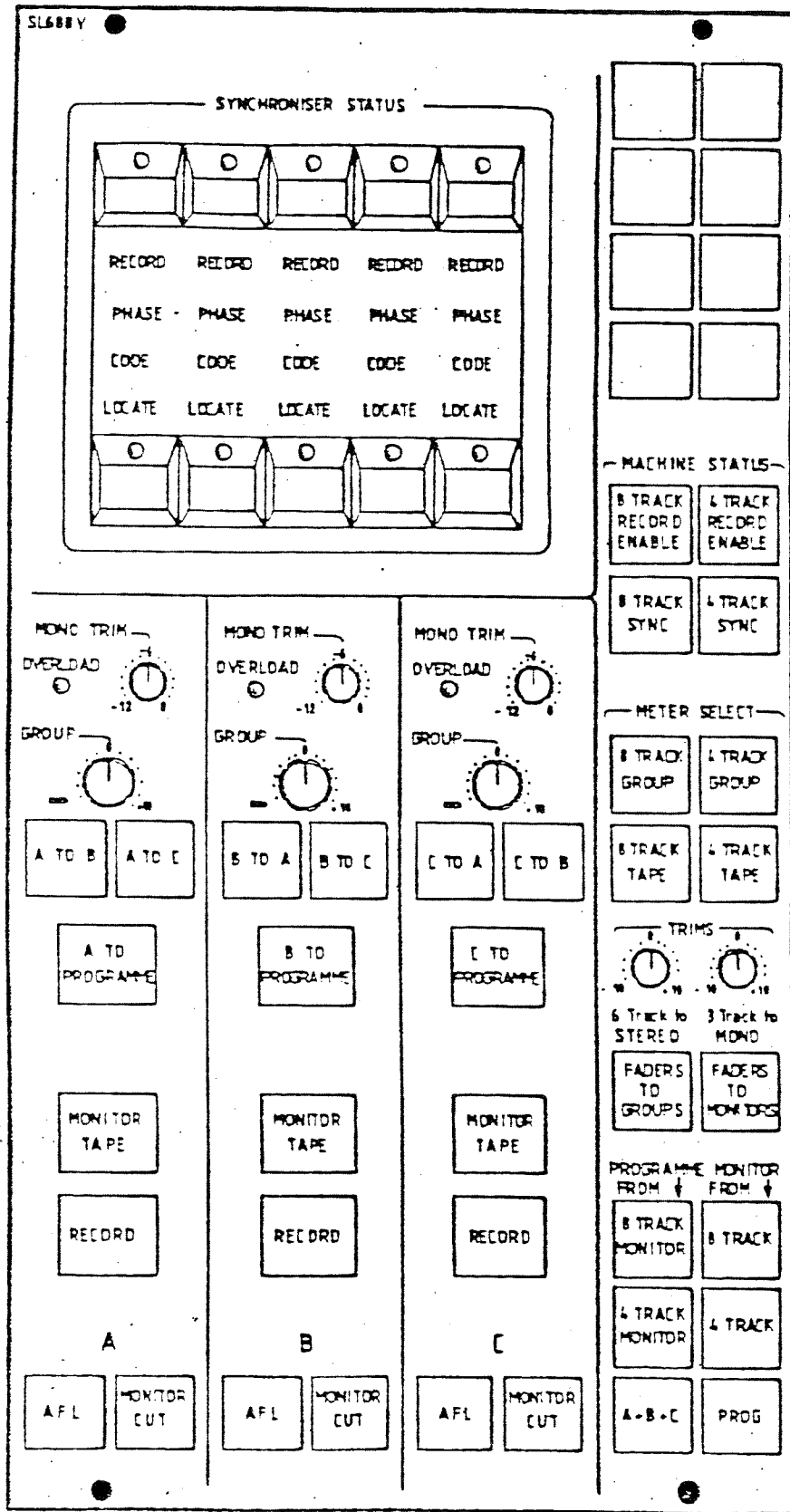

## OTHER CONTROLS

**FADER POSITION BUTTONS** - As mentioned, a fader which controls mono and stereo VCAs is located beneath each of the three Local Control Areas (A, B and C). When the operator is creating Music, Dialogue and Effects tracks which are to be recorded at unity gain, no Fader Position buttons need to be selected, and these faders and their VCAs are by-passed.

The 688 panel provides two pushbuttons which allow the engineer to place these faders in the required signal path.

**FADERS TO GROUPS** - In live production, or mixing operations where the A, B and C buses are being used as stereo audio subgroups, fader control is desirable.

**FADERS TO MONITORS** - Places the faders and the AFL switches after the Monitor Tape/Group switches. This mode is useful when the 688 panel is serving as a reduction mixer from the 8 or 4 TRACK Machines. It is also useful when PROGRAMME FROM A+B+C and the 8 or 4 TRACK has been selected, allowing fader control over the external or tape signals which are to mixed into the A, B and C buses.

**STATUS LOCK FUNCTIONS** - When the STATUS LOCK button on the 651 is activated certain facilities are locked to prevent accidental selection or deselection during live or important recordings. STATUS LOCK does the following:

The PROGRAMME FROM buttons are locked in their present position. If this status is PROGRAMME FROM A+B+C the local TO PROGRAMME buttons are locked. If PROGRAMME FROM 8 TRACK (or 4 TRACK) is selected, the MONITOR TAPE BUTTONS are locked.

**SYNCHRONISER STATUS CONTROLS** - The upper left quadrant of the SL 688-V panel contains the controls and displays for the SSL Integral Synchroniser. This synchroniser status display panel is fitted to all SL 688-V panels, whether or not the Integral Synchroniser option is included, to facilitate fast field retrofit of the system.

The SSL Integral Synchroniser system is fully described in the SL 6000E Series brochure and the Studio Computer Instruction manual.

**OVERLOAD INDICATORS** - An overload warning LED is provided in each of the A, B and C section which lights when the signal is 3dB below clipping. The detector monitors the left, right and mono signals in both the Group and Monitor paths

**USER OPTION SWITCHES** - At the top of the panel are 8 user option switches. These are for use by the studio for custom facilities.

THE SL688V MIX MATRIX PANEL

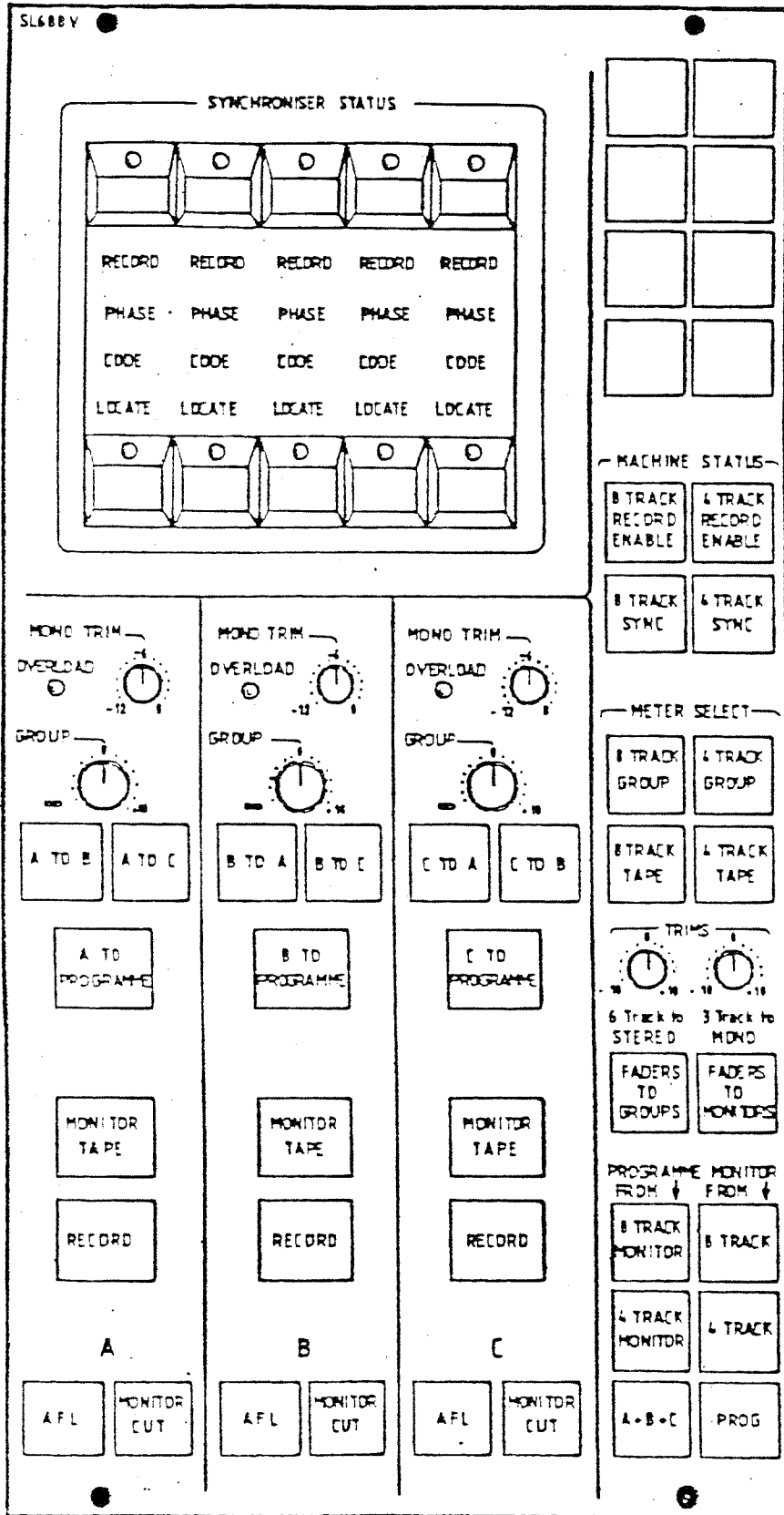



## SECTION 8

### THE PATCH

The Solid State Logic SL 6000 E Series patchbay comes with a minimum of 18 rows of bantam (TT) mini-jacks divided into 1U high patchrows each with 2 rows of jacks.

Each row contains 48 jacks, although consoles with mainframe sizes greater than 48 channels come supplied with 56 jacks per row. The patch is logically divided into paired rows, the upper jack being the output feed and the lower jack being the input feed. There are two types of normalling used within the patch:

**HALF-NORMALLED** - Top row is an output listen (bridging) jack. If a jack is inserted into the top row it receives the feed on that socket but does not break the normalling down to the row below. The outers are wired down to the inners (blades) of the row below. The bottom row is an input jack and when a patchcord is inserted in the bottom row it breaks away the normalled feed from the row above.

**FULL NORMALLED** - Top row inners are wired to the bottom row inners. A jack plugged into either the top or bottom row will break the normalling.

Only the first two rows of jacks (the mic lines and the channel mic inputs) are fully normalled to prevent a microphone from being plugged to two channel inputs. Most of the other rows are half normalled, apart from the user option rows R and S (unless they were specifically specified as being normalled by the studio). Any additional rows fitted may or may not be normalled and you should check this with the studio.

Rows A to K are fairly obvious with these exceptions and notes:

The multitrack returns (ie. multitrack outputs) split on entering the console and feed both rows C and J.

The channel insert send jacks always have signal present. It is the return into the module that is switched by the insert IN switch. Useful for setting input levels on effects devices before switching them in, and also useful as additional feeds from each module.

Group outputs on row G are after the GROUP TRIM control. These normal down into row H. Row H feeds the multitrack sends (ie. the multitrack inputs) and also the READY GROUP monitoring button. Hence the READY GROUP button on a channel will always monitor the multitrack send even if the groups have been cross patched.

Some jacks are cross normalled and these are detailed below together with certain inputs and outputs, the wiring of which may not be immediately obvious:

INSERTS A, B and C (L1-6,M1-6) - These insert points appear in the A, B and C stereo groups after the GROUP TRIM control but prior to the fader and routing to Programme and A, B or C groups.

PROGRAMME (L7-9) - L7 and L8 are the main programme output jacks normalled down to the stereo distribution inputs (jacks M7 and M8). These stereo distribution jacks are wired to the outers of the stereo feed jacks (L27-L36). Each pair of these jacks carries the stereo programme output and each pair is normalled down to its' corresponding machine input (M27-36).

MON INSERT L, R, M (L10-12, M10-12) - These are the insert jacks which follow the 6 TRACK TO STEREO and 3 TRACK TO MONO controls.

OSC (L13 & 14) - Yes the oscillator! The jacks below (M 13 & 14) feed to the tone distribution system via the OSC TO PROGRAMME and GROUPS buttons, and are useful for feeding an external oscillator or noise source to the desk outputs.

8 TRACK A1,Ar,B1,Br,C1,Cr (L15-22) - These are the Stereo A, B and C Group outputs which are normalled down to jacks that can be wired to an 8 Track machine.

A,B,C (L23-25) - These are the mono derived feeds of the A, B and C group outputs which are normalled down to the row below which can be wired to a 4 Track machine.

ECHO SENDS (N1-4) - These carry the AUX 1 to 4 outputs which are normalled down to the effect send lines (P1-4) out of the console. Jacks P1 and P2 are also wired to jacks N7 and N8 which, together with the stereo send outputs on N5 and N6 are normalled back into the console (via jacks P5-8) for the addition of talkback, stereo echo and stereo external sources. These Cue outputs then emerge on jacks N9-14 as three stereo cue sends.

8 TRACK REP and 6 BUSS MATRIX (note the spelling mistake) (N15-22 and P15-22) - The eight track machine replay outputs may be wired into the SL 688-V Stereo tape monitor inputs via these jacks.

4 TRACK REP and MATRIX (N23-26,P23-26) - The 4 track replay outputs may be wired in a similar way to the above.

ST1 to ST5 REP (N27-36,P27-36) - Up to 5 stereo returns may be wired to these jacks. The inputs to the external selectors can be found on jacks P27-36.

DISC (N37-38,P37-38) - A disc (or any stereo replay device) may be wired into the external selector via these jacks.

SLS (N39-40,P39-40) - The SLS outputs are normalled down to the power amp feed.



MD (N41,P41) - N41 has the switched MD talkback feed which is normalled out of the console on jack P41.

VTR MON (N42-43,P42-43) - Another external selector monitor input to the desk, this time designated VTR for connection to a Video machine.

AIR MON (N43-44,P43-44) - Yet one more input to the external monitor selector, for off-air monitoring.

LISTEN MICS (R39-40,S39-40) - If listen mics have been wired they will appear on jacks R39-40 and are normalled into the console listen mic inputs S39-40. This insert point is convenient if other mics need to be used as listen mics.

SMPTE JACKS (R39-48,S39-48) - These 16 jacks are designed to be used with the SSL Integral Synchroniser System. They provide comprehensive patching for up to three machine SMPTE sends and returns. SMPTE from three machines, A, B and C come in on jacks R41-43 and are normalled down to the inputs to the three way Master Transport Selector. The selected SMPTE (from the master machine) returns to the patch on jack R44 and is then normalled down to the SSL Studio Computer SMPTE input S44. The Primary computer SMPTE generator output (which reshapes any code fed into S44) appears on jack R45 and is normalled to the three distribution jacks R46-48 via the insert jack S45. These three feeds of generated SMPTE are then normalled into the A, B and C machine SMPTE record inputs via jacks S46-48.

#### STEREO MODULES

If the patch has been wired to accept stereo modules then it will be slightly different from the drawing. The usual practice is to wire all the I/O modules to jacks A to K as shown. Stereo modules may be wired to rows R, S, T & U as follows:

Say, for example, 4 stereo modules have been specified. Stereo lines from the studio, or control room will appear on jacks R 1-8. Stereo module inputs will be normalled down from R 1-8 into S 1-8. Stereo insert sends and returns will appear on jacks T1-8 and U 1-8. Another alternative would be for the Lines and Line inputs to be wired to R&S 1-8 and the inserts to R&S 9-16.

For consoles with a mainframe size of 56 or more a 56 wide patch is usually fitted to accommodate the extra inputs. In this case the SMPTE jacks are moved from rows R&S to rows N&P at the right hand end.

The majority of consoles are supplied with integral patchbays, however, as an option, versions with remote patchfields are available. The layout and the normalling will be the same.

#### SL 688-V SIGNAL FLOW AND THE PATCH

The diagram opposite shows basic signal flow through the SL 688-V module with respect to insert points and main output jacks.

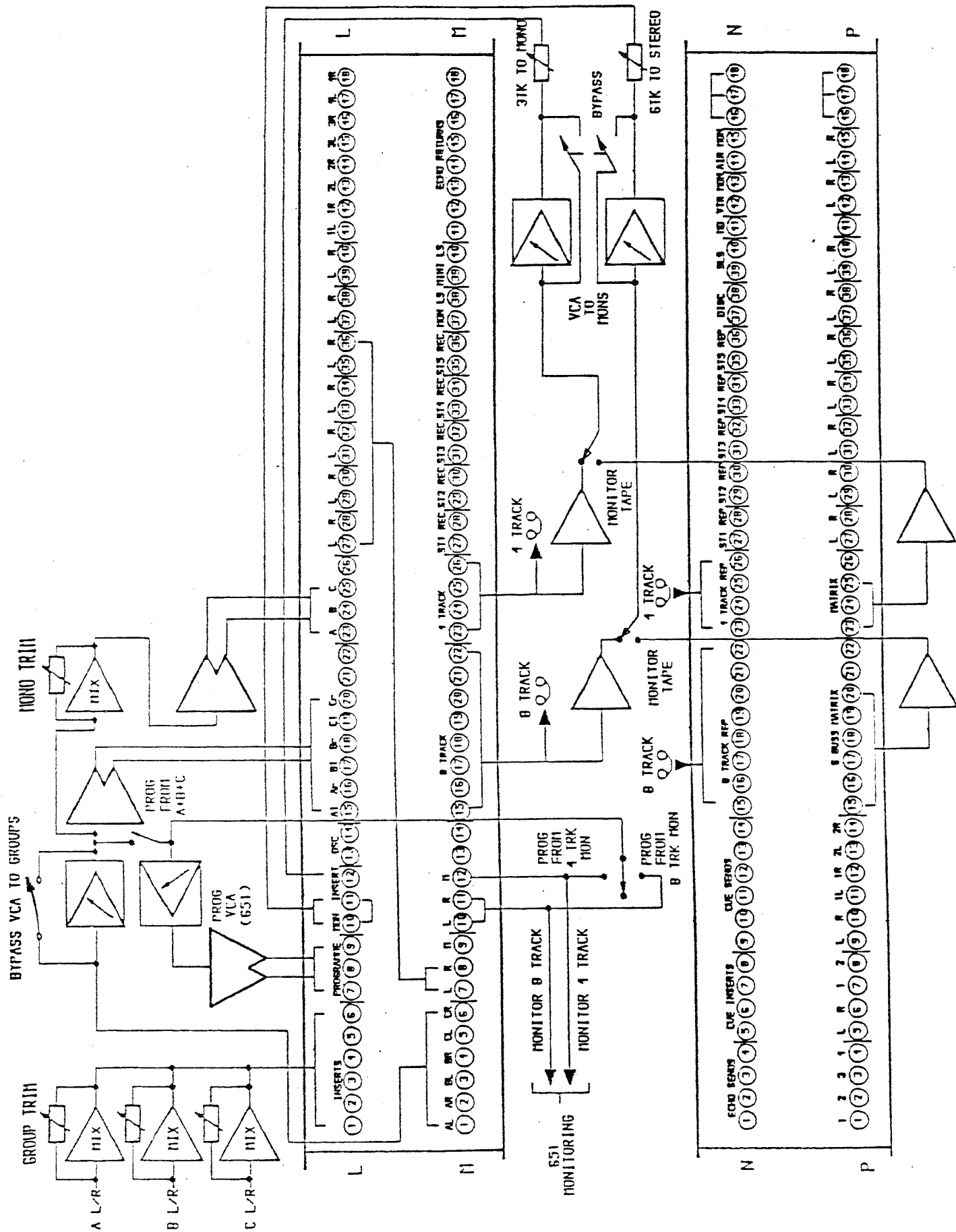

This page has also been left intentionally blank.