



## INSTRUCTIONS FOR

# Booster Amplifier

## TYPE BA-2A

(MI-11226)

### DESCRIPTION

The MI-11226 Booster Amplifier, Type BA-2A, is a two-stage voltage amplifier designed to raise the audio output of low-level transcription turntable pickups to an adequate level for mixing with other program material. The amplifier can also be used at transmitter locations to operate between an announce microphone and a limiting amplifier. The booster amplifier has a self-contained power supply designed to operate from a source of 105 to 125 volts, 50 to 60 cycles. It uses plug-in-type electrolytic capacitors, and contains an interstage volume control and an ON-OFF switch. The chassis has a plug-in type of base construction. Also included are various hardware items necessary

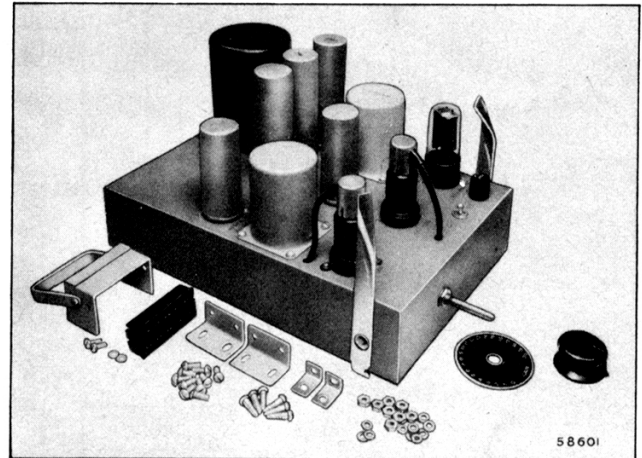

Figure 1—Type BA-2A Booster Amplifier

### TECHNICAL DATA

#### Power Supply

105 to 125 volts  
50 to 60 cycles  
15 watts

#### Fuse Rating

1 ampere

#### Radiotrons\*\*

2 RCA-1620 or †2 RCA-6J7  
1 RCA-6X5 or 1 RCA-6X5 GT/G  
† May be used when maximum uniformity of characteristics, and minimum of microphonics, hum and distortion are not required.

#### Source Impedance

250 or 30 ohms

#### Input Impedance

Greater than source impedance, unloaded input transformer.

#### Maximum Input Level

—26 dbm\* for 1% or less total rms distortion from 50 to 7,500 cps.

#### Output Impedance

250 or 480 ohms

\*dbm = decibel level referred to 1 millwatt

#### Load Impedance

250 or 600 ohms

#### Noise Level

—72 dbm\* with input terminated and maximum gain.

#### Gain

50 db from 250-ohm source to 600- or 250-ohm load.

#### Power Output

+2 dbm\* with less than 1% total rms distortion from 30 to 15,000 cps.

#### Frequency Response

±1.5 db from 30 to 15,000 cps (250- or 30-ohm source to 600- or 250-ohm load).

#### Mounting

- Shelf mounting in the Type 36-B or Type BR-2A Panel-and-Shelf assemblies.
- Cabinet mounting in 70-A, 70-B, 70-C, or 70-C1 Transcription Turntable assemblies.

#### Dimensions and Weight (overall)

Length—14 inches  
Width—8 inches  
Height—6½ inches  
Weight—11 pounds

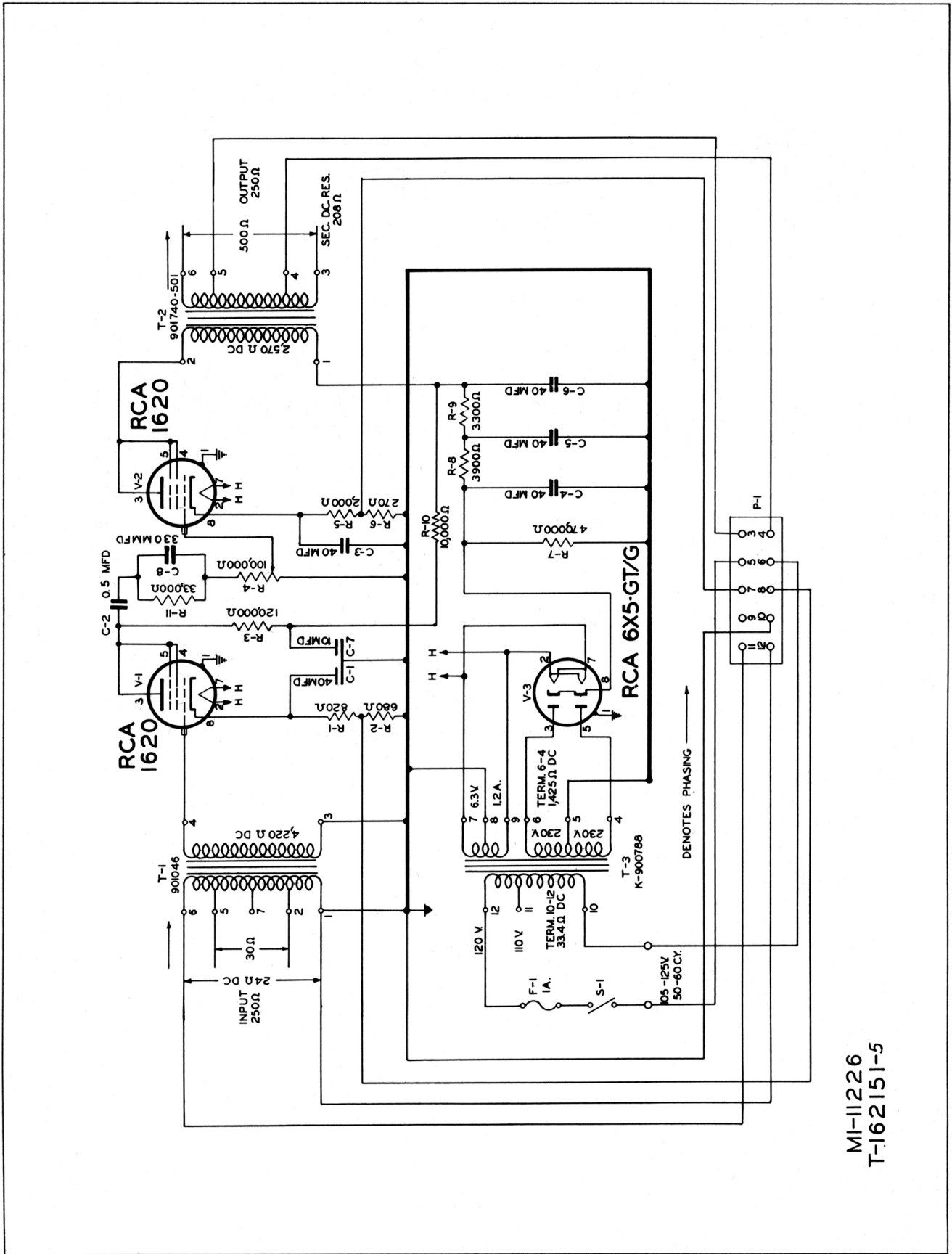

Figure 2—Schematic Diagram

for mounting purposes, two handles, mounting brackets and a socket cover. All connections from the amplifier are made to a 10-terminal plug at the rear of the chassis. A mating receptacle to match this plug is furnished with the amplifier.

## INSTALLATION

### Assembly

When the equipment is received, place all plug-in capacitors and tubes in their proper sockets. Each capacitor is marked with its capacity and voltage rating and similar markings on the chassis near the sockets indicate the proper sockets. The tube marking and designations on the chassis also correspond. Place the grid leads on the two Type-1620 tubes, and fasten the grid-shield cans over them. Place the knob on the shaft and tighten the setscrew. (When mounting on 36-B shelf, first install GAIN dial.) If the amplifier is to be mounted on a BR-2A shelf, attach the two handles to the chassis by means of the two pivots, C washers and spring washers. These handles should be mounted through mounting holes on the sides of the chassis near the front.

### Mounting

The MI-11226 Type BA-2A Booster Amplifier is designed to be mounted either inside a turntable cabinet or on a mounting shelf.

#### Mounting on Type 36-B Panel and Shelf

To mount the amplifier on a Type 36-B or similar shelf, first attach the two mounting brackets to the rear of the chassis by four machine screws, hex nuts and lockwashers. Fasten the chassis to the shelf with four machine screws through the mounting-bracket holes and the holes in the rear of the shelf. Washers and nuts should be used with the screws. Mount the GAIN dial.

#### Mounting on Type BR-2A Panel and Shelf

To mount the amplifier on a Type BR-2A or similar shelf, slide the amplifier chassis onto the shelf so that the chassis plug fits into the receptacle at the rear of the shelf.

#### Installation in RCA Turntable Cabinets

Whenever the amplifier is mounted in a transcription turntable, attach the four mounting brackets to the chassis by six machine screws, nuts and lockwashers. Attach the cover plate beneath the chassis so that the mounting holes in the cover plate line up with the six bracket-mounting holes. Mount the entire unit in the turntable cabinet by six No. 8 wood screws.

When the Type BA-2A Booster Amplifier is to be used with a Type 70-C1 Transcription Turntable, mount the amplifier on the right wall of the cabinet beneath the filter unit and near the front. If it is desired to install the amplifier in a Type 70-C Transcription Turntable mount the chassis on the right wall of the cabinet, near the front, with the volume control on the top. When the amplifier is used with a Type 70-A or 70-B Transcription Turntable, mount the amplifier on the left wall of the cabinet, near the front, with the volume control at the bottom.

## CONNECTIONS

### Amplifier Connections

All connections are made to the receptacle at the rear of the chassis. This receptacle has 10 solder-type terminals numbered according to the corresponding pin on the amplifier connecting plug.

### Audio Input Connections

Connect the incoming audio line (unbalanced) to the terminals marked 11 and 12, the high side of the line to terminal 11. These terminals are connected to the 250-ohm primary of the input transformer T-1 (terminals 1 and 6, unbalanced). This connection is standard for this amplifier, and is correct for operation from any 250- to 300-ohm unbalanced source.

To match a 30- to 50-ohm source (unbalanced) with this amplifier, disconnect the leads from the 250-ohm primary of the input transformer T-1 (terminals 1 and 6), and connect them to the 30-ohm primary (terminals 2 and 5, with the green-yellow lead on terminal 2). Disconnect the ground lead from terminal number 1 on transformer T-1 and connect it to terminal 2.

Whenever a balanced source is used, remove the ground lead from the input transformer primary (terminal 1 or 2).

### Audio Output Connections

The Type BA-2A Booster Amplifier is designed to work into a load of 250 ohms or 600 ohms. It will operate satisfactorily into amplifiers such as the Type 86-A or 86-A1 Limiting Amplifier, the 82 Series of monitoring amplifiers, and the 84 Series and BA-3A Series of program amplifiers.

The output terminals, 3 and 4, are normally connected to the 250-ohm secondary of the output transformer T-2 (terminals 4 and 5). This is correct for matching any 250-ohm load.

To match a 600-ohm line or load, disconnect the leads from the 250-ohm secondary of the output transformer T-2 (terminals 4 and 5), and connect these leads to the 600-ohm secondary (terminals 3 and 6).

When an unbalanced output is desired, connect output transformer terminal number 3 or number 4 to ground, depending upon which terminal is connected to the amplifier plug.

**Connections to Turntables**

When the BA-2A amplifier is used with a Type 70-C1 Transcription Turntable, connect the output of the pickup filter circuit directly to the terminals numbered 11 and 12 on the amplifier receptacle (black lead to terminal 11).

Refer to figure 3 for the connection diagram when the BA-2A amplifier is used with a Type 70-C Transcription Turntable and Type 71-C Vertical Pickup Kit; or when the BA-2A is used with a Type 70-A or 70-B Transcription Turntable and Type 71-A, 71-B, or 71-B1 Vertical Pickup Kit. Disconnect leads at terminals 1, 2 and 3 on the turntable output terminal board and reconnect to Type BA-2A as shown.

**A-C Power Connections**

Connect the A-C power line to the two terminals

numbered 5 and 6 on the Type BA-2A terminal board. The power transformer T-3 is designed for operation on 105 to 125 volts, 50 to 60 cycles, and is connected at the factory for 115- to 125-volt operation. If it is known that during the operating period the voltage is between 105 and 115 volts, disconnect the red lead to terminal number 12 of the power transformer and connect this lead to terminal number 11 of T-3.

*CAUTION: Do not connect the a-c power leads until all other wiring to the amplifier is complete.*

**Receptacle and Socket Cover**

If the Type BA-2A is mounted in a location where it is necessary to use the receptacle furnished with the amplifier, fit this receptacle over the chassis plug. After connections have been made to external circuits, screw the socket cover to the receptacle, using two binder-head screws and lock-washers. This socket cover includes a bracket to facilitate removing the receptacle without pulling on a cable.

**SERVICE**

**Metering Terminals**

To make a check of the operation of the first stage RCA-1620 Radiotron, connect a voltmeter across terminals 8 and 10. Likewise, to make a

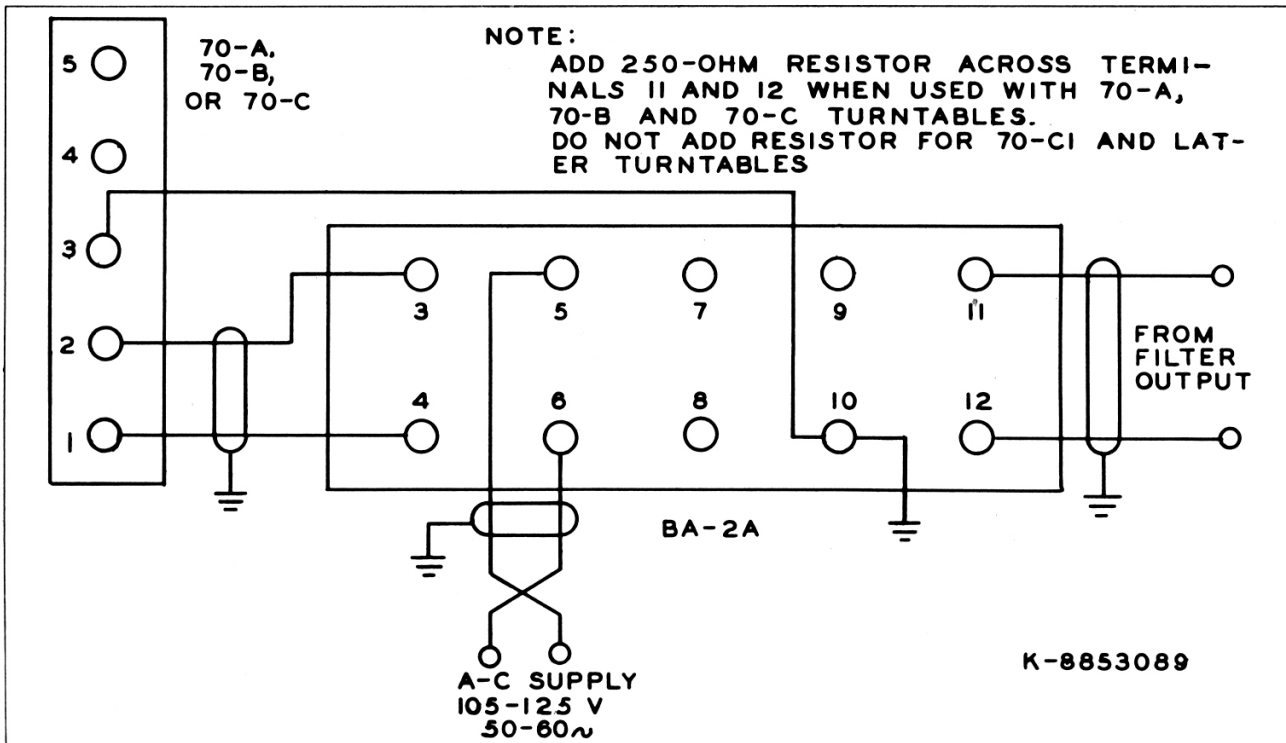

Figure 3—Connection Diagram

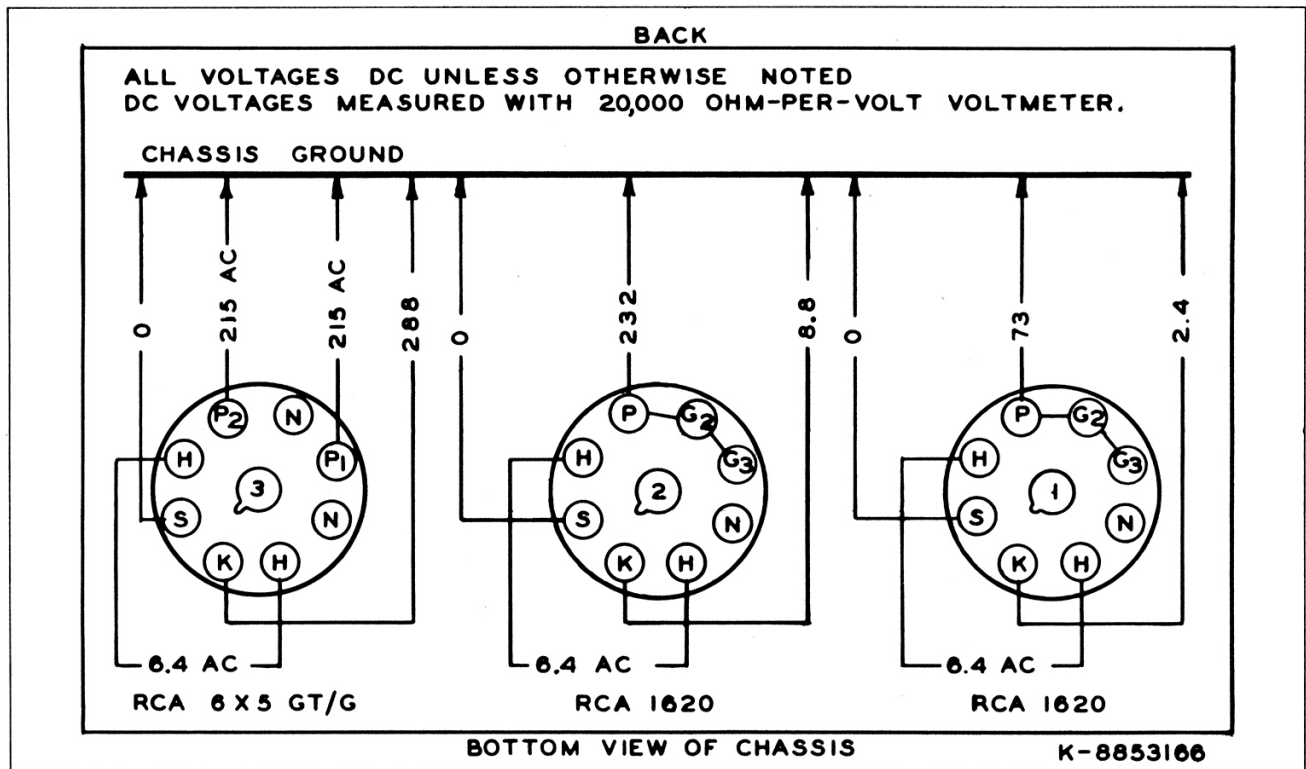

Figure 4—Tube Operating Voltages

check of the second stage RCA-1620 Radiotron, connect a voltmeter across terminals 7 and 10. Use a 5.0 or 7.5 volt d-c meter of 20,000 ohms-per-volt with the negative lead placed on terminal 10. When the stages are functioning properly, each reading should be approximately 1 volt. A rack-type meter panel MI-4388, Type 15-D, complete with meter and switch may be used with the Booster Amplifier.

#### Operating Voltages

Refer to figure 4 for tube operating voltages. To obtain the values listed, the a-c line voltage should be 117 volts, and all except heater voltages should be measured to ground using a voltmeter of 20,000

ohms-per-volt. The voltages listed are nominal, and readings taken should not vary more than about 5 per cent of the values given. The total rectifier voltage (across C-4) should be approximately 292 volts.

#### Replacement Parts

The following parts list is included to provide identification when ordering replacement parts. Order from RCA Replacement Parts Department, Camden, New Jersey, giving the *stock number* and *description* of the parts wanted. Replacement parts supplied may be slightly different in form or size from the original parts but will be completely interchangeable with them.

### LIST OF PARTS

Symbol No.	Description	Stock No.
C-1, C-7	Capacitor; 10 mf, 450 v; 40 mf, 25 v	39461
C-2	Capacitor; 0.25 mf, 300 v	30849
C-3	Capacitor; 40 mf, 150 v	39459
C-4, C-5, C-6	Capacitor; 40 mf, 450 v	39457
C-8	Capacitor; 270 mmf, 400 v	39638
F-1	Fuse; 1 amp, 250 v	14133

Symbol No.	Description	Stock No.
P-1	Connector, male	48788
R-1	Resistor; 820 ohms, $\frac{1}{2}$ w	30158
R-2	Resistor; 680 ohms, $\frac{1}{2}$ w	12262
R-3	Resistor; 82,000 ohms, 1 w	30435
R-4	Resistor; variable, 100,000 ohms	19332
R-5	Resistor; 2,000 ohms, $\frac{1}{2}$ w	33573
R-6	Resistor; 270 ohms, $\frac{1}{2}$ w	30929

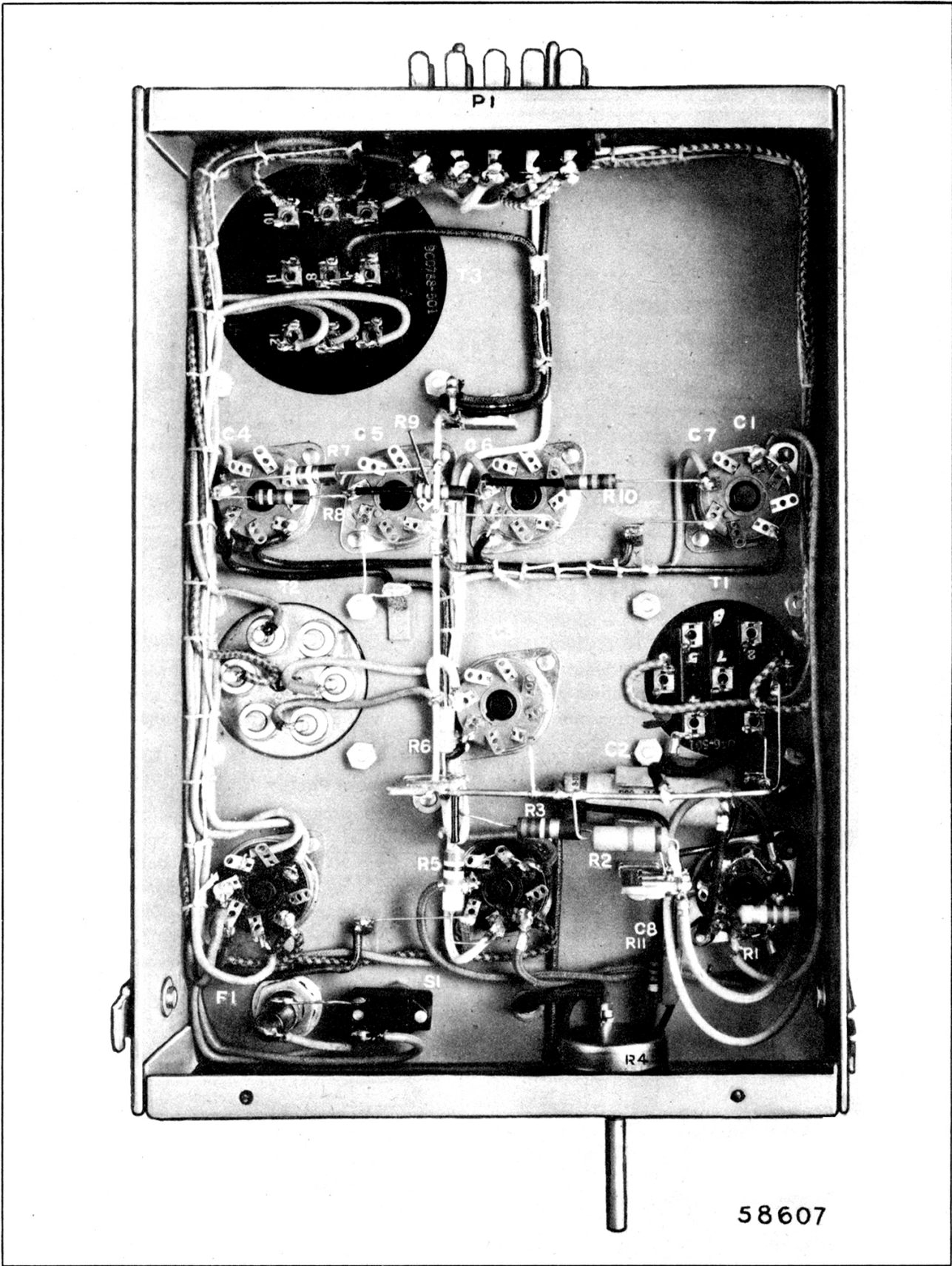

Figure 5—Amplifier (bottom view)

### LIST OF PARTS—(Continued)

<i>Symbol No.</i>	<i>Description</i>	<i>Stock No.</i>	<i>Symbol No.</i>	<i>Description</i>	<i>Stock No.</i>
R-7	Resistor; 470,000 ohms, 1 w	36243	.....	Handle, left; with pivot	52403
R-8	Resistor; 3,900 ohms, 1/2 w	30694	.....	Handle, right; with pivot	52404
R-9	Resistor; 3,300 ohms, 1/2 w	30733	.....	Holder, fuse	48894
R-10	Resistor; 10,000 ohms, 1/2 w	3078	.....	Knob, gain control	17268
R-11	Resistor; 33,000 ohms, 1/2 w	30685	.....	Shield, tube cap	12110
S-1	Switch, SPST	48791	.....	Socket, tube; octal type	31319
T-1	Transformer, input; (XT-3635)	43569	.....	Socket, octal type for capacitors	45368
T-2	Transformer, output; (XT-2875-2)	18051	.....	Socket, tube; octal type for rubber shock mounting	28413
T-3	Transformer, power; (XT-3367)	19955	.....	Washer, C	8078
.....	Connector, female	49032	.....	Washer, spring, C	2917
.....	Cushion, socket	4570			

**RADIO CORPORATION OF AMERICA**  
RCA VICTOR DIVISION                      CAMDEN, N. J.